



613-000761 Rev.A 070328

TELESYN<sup>®</sup> Series  
Services Guide  
Issue 1  
Release 8.0

## Introduction

Congratulations on your purchase of a Telesyn™ product. This product is part of a family of products that leverages Ethernet switching technology to offer service providers a range of services, including data (low and high speed) video, and voice.

## Who Should Read This Guide?

Service provider staff who are involved with the implementation of data, video, and voice services. This document provides an outline for the engineering and provisioning of these services using the various technologies (ADSL, SHDSL, etc.) available with the Telesyn product.

## About this Guide

This guide includes:

- Section 1 provides an outline of the document and shows the user how to access necessary information and procedures.
- Section 2 shows how data services are provided (such as by SHDSL), and the important network, hardware, and software considerations to take into account.
- Section 3 shows how video data are provided (such as by ADSL), and the important network, hardware, and software considerations to take into account
- Section 4 shows how voice services are provided (such as by the POTS24 card), and the important network, hardware, and software considerations to take into account
- Section 5 describes Circuit Emulation Service (CES), which provides DS1/E1-based services to subscribers while shifting to a packet-based infrastructure for the rest of the network.
- Section 6 describes Ethernet Passive Optical Network (EPON) and traffic considerations.
- Section 7 explains any special configurations and how they can be incorporated into the provider's network.
- Section 8 shows some sample configurations that optimally combine the services described in the previous sections. The sample configurations include provisioning at the network level (such as Protection Switching).

# Table of Contents

---

<i>1 What this Guide Provides</i>	<i>-1-1</i>
<b>1.1 Overview</b>	<b>1-1</b>
<b>1.2 How this Document is Organized</b>	<b>1-1</b>
1.2.1 Definition of Terms	1-1
1.2.2 Document Sections	1-2
1.2.3 Final Section (Provisioning Example)	1-3

---

<i>2 Optimizing Data Services (SHDSL)</i>	<i>-2-1</i>
<b>2.1 Overview</b>	<b>2-1</b>
<b>2.2 Technology Implementation</b>	<b>2-3</b>
2.2.1 Standards	2-3
2.2.2 Telesyn Implementation	2-3
<b>2.3 Features</b>	<b>2-4</b>
<b>2.4 Hardware Provisioning</b>	<b>2-5</b>
2.4.1 Port Numbering	2-5
2.4.2 CPE Devices	2-5
<b>2.5 Software Engineering</b>	<b>2-6</b>
2.5.1 Interface Association	2-6
2.5.2 Conversion from Normal to Bonded SHDSL	2-6
2.5.3 SHDSL Port Audit	2-7
2.5.4 SHDSL RMON Statistics	2-8
2.5.5 SHDSL PMON	2-8

---

<i>3 Optimizing Video Services</i>	<i>-3-1</i>
<b>3.1 Overview</b>	<b>3-1</b>
<b>3.2 Video Services provided by ADSL</b>	<b>3-1</b>
3.2.1 Overview	3-1
3.2.2 Technology	3-3
3.2.3 Features	3-3
3.2.4 Network Engineering	3-5
3.2.5 Software Engineering	3-10

3.2.6 Maintenance	3-21
3.2.7 Loop Length and Data Rates (Rate vs. Reach) for ADSL Modes	3-23
<b>3.3 Video Services Provided by Fast Ethernet/Fiber</b>	<b>3-23</b>
3.3.1 Overview	3-23
3.3.2 Technology	3-25
3.3.3 Features	3-25
3.3.4 Network Engineering	3-25
3.3.5 Software Engineering	3-25
3.3.6 Maintenance	3-34

---

## *4 Optimizing Voice Services* ----- 4-1

<b>4.1 Overview</b>	<b>4-1</b>
<b>4.2 POTS Only with Call Agent (POTS24 Card)</b>	<b>4-1</b>
4.2.1 Overview	4-1
4.2.2 Technology	4-2
4.2.3 Features	4-3
4.2.4 Network Engineering	4-4
4.2.5 Hardware Provisioning	4-5
4.2.6 Software Engineering	4-6
<b>4.3 Derived Voice (Residential Gateway)</b>	<b>4-7</b>
4.3.1 Overview	4-7
4.3.2 Telesyn Implementation	4-7

---

## *5 Circuit Emulation Service (CES)* ----- 5-1

<b>5.1 Overview</b>	<b>5-1</b>
<b>5.2 Technology</b>	<b>5-1</b>
<b>5.3 Features</b>	<b>5-1</b>
<b>5.4 Network Engineering</b>	<b>5-4</b>
5.4.1 Packet Network Considerations	5-4
5.4.2 NUMBYTES and Bandwidth Correlation	5-6
5.4.3 NUMBYTES vs. Minimum / Maximum Jitter Values	5-7
<b>5.5 Software Engineering</b>	<b>5-10</b>
5.5.1 Statistics	5-10

---

## *6 Ethernet Passive Optical Network (EPON)*----- 6-1

<b>6.1 Overview</b>	<b>6-1</b>
---------------------	------------

---

<b>6.2 Traffic Management</b> .....	<b>6-1</b>
6.2.1 Classifiers .....	6-1
6.2.2 QoS (Traffic Queues/Priorities) .....	6-1
6.2.3 Connection Admission Control (CAC) .....	6-2
<b>6.3 Feature Interaction</b> .....	<b>6-3</b>
<b>6.4 Technology</b> .....	<b>6-4</b>

---

*7 Special Network Configurations* - - - - - **7-1**

<b>7.1 Overview</b> .....	<b>7-1</b>
<b>7.2 FE10 Upstream Interface</b> .....	<b>7-1</b>
7.2.1 Overview .....	7-1
7.2.2 Feature Interaction .....	7-1

---

*8 Optimizing All Services (Triple Play)* - - - - - **8-1**

<b>8.1 Overview</b> .....	<b>8-1</b>
8.1.1 Sample Configuration - Network Level .....	8-1
<b>8.2 Provisioning Example - Overview</b> .....	<b>8-2</b>



# 1. What this Guide Provides

---

## 1.1 Overview

The Telesyn documentation set includes the Telesyn User Guide and Reference Guides. These Guides provide the user an overview of the products that make up the Telesyn product set, the features that are provided for these products, and the parameters, measurements, audits, and logs that are used to activate and use these features.

Starting from the information provided in these Guides, this document is intended to give the user recommendations on how to:

- Engineer the system before physical provisioning
- Help configure key parameters and measurements so that services can be provisioned to meet the engineering requirements
- Monitor the systems so that problems (and potential problems) can be more effectively recognized and resolved.

*Note: This document is not intended to give the user a complete overview of all aspects of the Telesyn product; that is provided in the Telesyn User Guide. By reading this Guide, the user can see what features are available and how to optimally use these features.*

---

## 1.2 How this Document is Organized

### 1.2.1 Definition of Terms

Terms such as services, features, applications, products, technologies, solutions, etc. are often used when describing various products in the network and their capabilities; to help the reader, these terms are explicitly defined here since they help in understanding the organization of this Guide:

- **Service** - Telesyn products provide what is called Triple Play, and these are the three services that providers wish to make available to their customers: Video, Data, and Voice.
- **Technology** - The Telesyn products employ the technologies that are suited to provide a service, such as SHDSL for high-speed data. These technologies are based on standards that are both public and Telesyn-specific, and so these standards must be reviewed to ensure the provider knows how Telesyn meets/implements these standards.
- **Feature** - These are the functions used that allow the technology to meet the various standards. Since these functions can be in a hierarchy, features can be part of a larger Feature Group

---

This document will focus on the technologies that are used to provide these Services

## 1.2.2 Document Sections

For each section, there is an explanation of how to engineer, provision, and implement each service. For each service one or more of the following subsections may be included.

*Note: For some services, all of these subsections may not be included since they may not be relevant for the service; however the first three subsections (Overview, Technology, and Features) are always included.*

- **Overview** - This provides physical/functional figures of the configuration, allowing the user to see the main components involved.
- **Technology** - This lists any relevant standards that are followed and how Telesyn meets those standards.
- **Features** - This lists the features of the Telesyn that the configuration supports

*Note: In some cases the explanation of how a service interacts with the features provide enough information to allow the user to optimally provision the service.*

- **Network Engineering** - These are the tasks that are done before the components are provisioned (or even installed), and include traffic modeling as well as formulas that help the provider calculate the maximum or minimum numbers of components for various configurations. Ideally, the information would help the customer optimize a configuration for the following scenarios:
  - Telesyn products are providing most if not all of the functionality needed
  - Telesyn products are being included in a larger configuration that involves products from many sources
- **Hardware Provisioning** - This can be divided into two areas:
  - Physical - These are the guidelines for cards and cabling.
  - Functional - These are the critical parameters that must be data filled with certain values if the models described in the Network Engineering subsection are to be implemented.
- **Software Engineering** - This includes the software tools and parameters that allow providers to monitor what has been provisioned. This would include statistics (performance measurements), audits, statistic thresholds, test levels, QoS counts, etc.
- **Monitor/Maintenance** - This would include the logs/messages when components have errors and an explanation of how certain faults or patterns of faults can determine if Hardware Engineering/Provision and Software Engineering need to be changed because of these reports.

*Note: The CLI will be the primary interface used in these provisioning scenarios. These tasks can also be done with the Telesyn NMS, and they can be found in the Telesyn NMS User Guide and Administration Guide.*



### 1.2.3 Final Section (Provisioning Example)

The final section of this document provides a complete example that shows a large network that spans several devices, VLANs, and subnetworks, so the user can see how services are combined in real-world scenarios. This helps providers understand how Telesyn products fit into the network and their interactions with other products.

*Note: In this Section, the Telesyn NMS will be used in the provisioning scenarios. This will highlight how using the Telesyn NMS allows the provider to provision customers effectively and efficiently using a GUI interface as well as features such as profiles. Moreover, by using the Telesyn NMS, the provider can make network level changes (such as protection switching), easier and less prone to error.*



## 2. Optimizing Data Services (SHDSL)

### 2.1 Overview

Typically, SHDSL is used to provide a data services for business applications. It provides symmetric transmission at a 2.3Mbps data rate over one pair of copper telephone wires and supports service for data and voice. Two ports may be joined (bonded) to form a single link with double bandwidth (up to 4.6 Mbps).

Two geographically regional modes, Annex-A and Annex-B, are supported. Annex-A is normally used within North American networks, which employ T1 services, and Annex-B for European networks (E1 services). The following figures illustrate the SHDSL configuration.

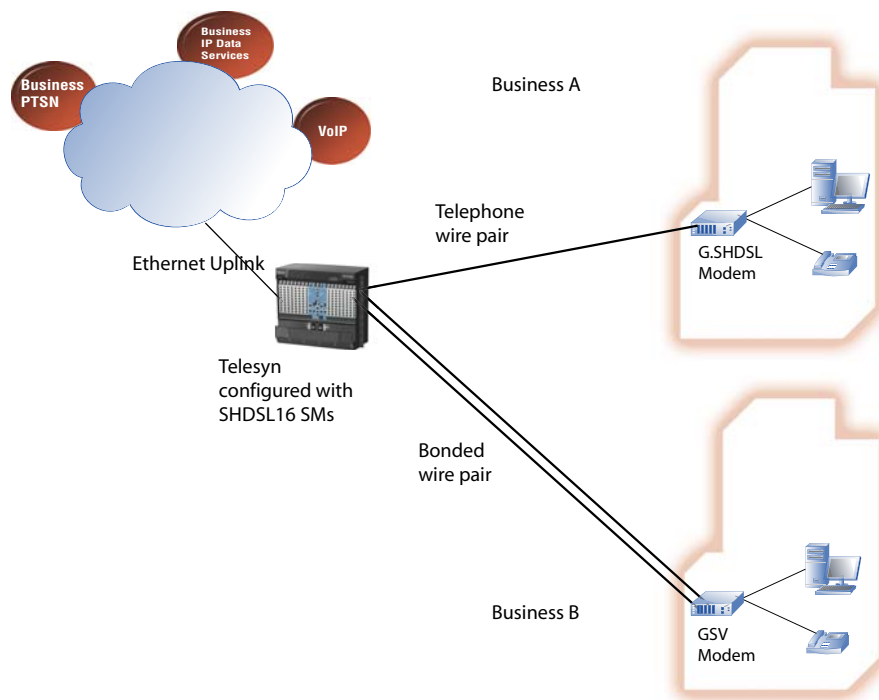

**FIGURE 2-1 SHDSL Configuration - Physical View**

## Overview

There are two modes for SHDSL:

- SHDSL Normal 2-wire - SHDSL (Symmetric Highspeed Digital Subscriber Line) is an international standard for symmetric DSL that provides for sending and receiving high-speed symmetrical data streams over a single pair of copper wires.
- SHDSL Bonding 4-wire -- Bonded mode joins two SHDSL ports resulting in a single port with doubled bandwidth. Adjacent wire pairs (e.g. 0&1, 2&3, etc.) on the SHDSL16 service module **must always be used**. This allows the SHLDS16 to support 8 4-wire bonded interfaces. Each bonded interface provides up to 4.6Mbps.

Figure 2-2 shows a functional view of the SHDSL configuration.

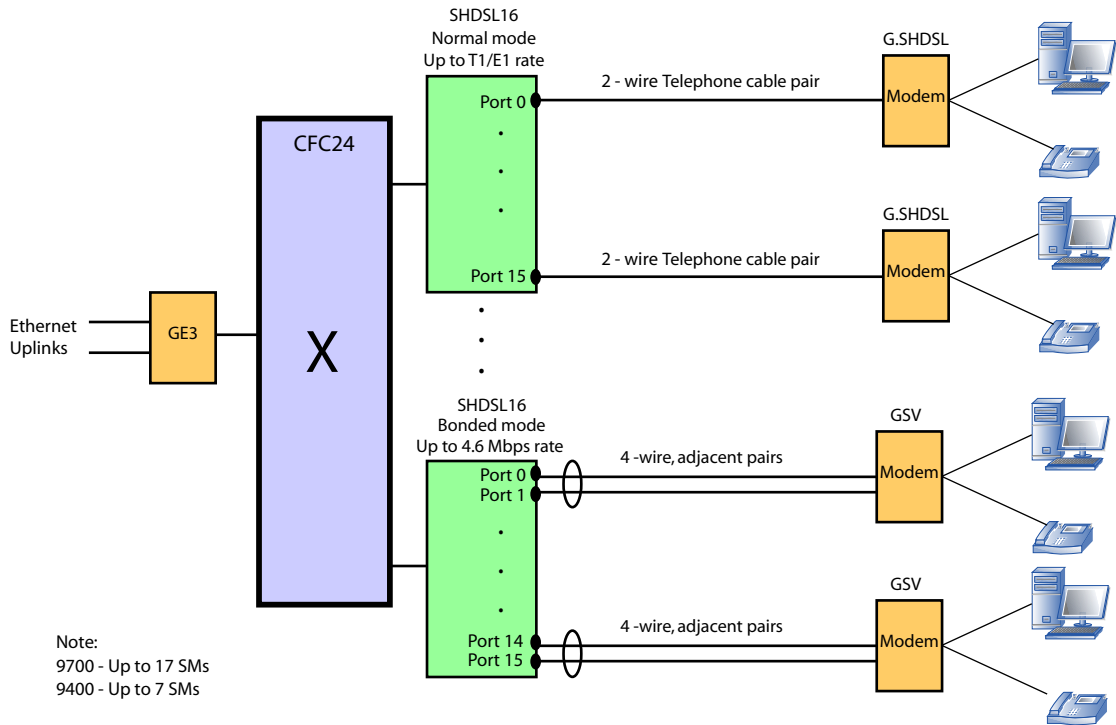

FIGURE 2-2 SHDSL Configuration - Functional View

## 2.2 Technology Implementation

### 2.2.1 Standards

Standard	Compliance	Notes
G.SHDSL Standard, ITU G.991.2 (Annex A & B)	Y	N/A
ITU G.994.1 (G.handshake, Handshake Procedures for Digital Subscriber Line (DSL) Transceivers)	Y	N/A

### 2.2.2 Telesyn Implementation

The Telesyn SHDSL16 service module provides symmetric transmission at a 2.3Mbps data rate over one pair of copper telephone wires, providing service for digital data. The SHDSL16 SM transports Ethernet packets encapsulated within ATM cells via RFC1483 bridging. The ATM cells are transported over twisted pair wiring with SHDSL encoding as AAL5. The subscriber CPE is a SHDSL modem that recovers the Ethernet packets from the ATM payload.

The following figure illustrates averages rates over specific loop lengths.

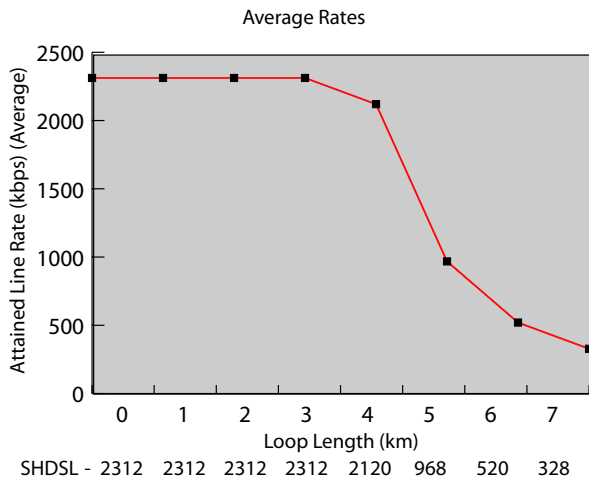

Modem - Xavi 3102r  
 Maximum Upstream Rate - 2312  
 Maximum Downstream Rate - 72

**FIGURE 2-3 Average rates for specific loop lengths**

## 2.3 Features

Following are the MAP and SM features supported by the SHDSL SM. See the *Telesyn User Guide* for information on provisioning these features.

**TABLE 2-1 Feature Interactions for SHDSL Service**

Feature	2-wire	4-wire	Notes
<b>Data Service</b>			
(VLAN)	Y	Y	
(UFO)	Y (VLAN based)	Y (VLAN based)	
(IGMPv2)	Y	Y	
(HVLAN)	N	N	
(VLAN Translation)	N	N	
Multicast channels			
MAC Limiting			
MAC Configuration			
DHCP Relay	Y	Y	
<b>Link Recovery</b>			
(STP)	Y	Y	
(RSTP)	Y	Y	
(LAG - Static)	Y	Y	
EPSR	Y	Y	
<b>QOS Classifier</b>			
Ethernet format	Y	Y	
IP Protocol	Y	Y	
IP Source	Y	Y	
IP Destination	Y	Y	
LSAP	Y	Y	
MAC Source	Y	Y	
MAC Dest.	Y	Y	
Layer 2 Protocol	Y	Y	
TCP Port Source	Y	Y	
TCP Port Dest.	Y	Y	

TABLE 2-1 Feature Interactions for SHDSL Service (Continued)

Feature	2-wire	4-wire	Notes
UDP Port Source	Y	Y	
UDP Port Dest.	Y	Y	
VID	Y	Y	
InnerVID	N	N	
Priority	N	N	
IP TOS	N	N	
IP DSCP	N	N	
TCP Flags	N	N	
VID Priority	N	N	
<b>Traffic Management</b>			
VLAN - VC Mapping	N	N	
IP Filtering	Y	Y	
ARP Filtering	Y	Y	
MAC Limiting	Y	Y	
Remarking	N	N	
Ingress Metering/Policing	Y	Y	
Queue Mapping	Y	Y	
Egress Rate Limiting	N	N	
No. of Queues	4	4	
ACL	Y	Y	

## 2.4 Hardware Provisioning

### 2.4.1 Port Numbering

SHDSL ports are numbered 0 through 15. Once in bonded mode, the bonded ports are identified by *even* port numbers only (0, 2, 4, 6, 8, 10, 12, 14) and only 8 bonded ports are presented to the user for configuration.

### 2.4.2 CPE Devices

For SHDSL Normal (2-wire) or Bonded (4-wire) service, an equivalent G.991.2 modem is required at the subscriber's premises.

The SHDSL16 also supports non-standard 4-wire operation to older Globespan CPEs.

Also, adjacent ports or wire pairs on the SM must be used when cabling a subscriber line for 4-wire service.

## 2.5 Software Engineering

### 2.5.1 Interface Association

In bonded mode, each bonded port (consisting of 2 physical pairs, represented by the even numbered port) has the following associated interfaces:

- Two SHDSL interfaces, one for each physical pair
- One ATM interface is multiplexed over the two “bonded” ports
- At least one AAL5 Virtual Channel interface for the bonded port
- At least one ETH interface for the bonded port

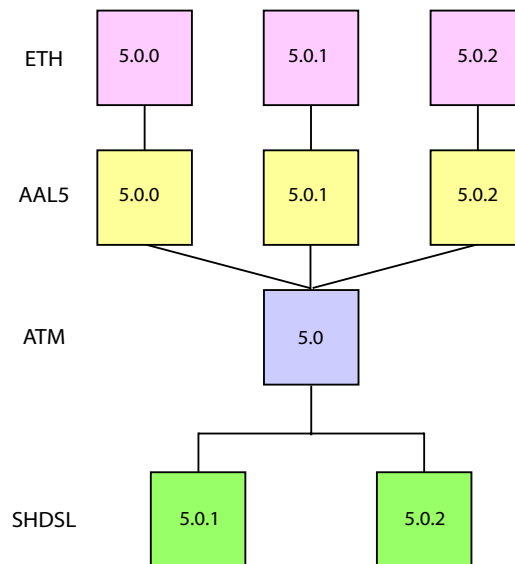

**FIGURE 2-4 SHDSL Interface Association**

All attributes are applied to both wire pairs of the bonded port and the maximum connect rate and minimum connect rate range is increased to 4624 (2312 x 2).

*Note:* Bonded interfaces only connect at the MaxConnectRate; the MinConnectRate parameter may be ignored.

In bonded mode, each physical wire pair can have differing runtime attributes, depending on external conditions of each physical wire pair.

### 2.5.2 Conversion from Normal to Bonded SHDSL

*Note:* This does not apply to Release 5.0.



The following walk-through assumes that card16 is a SHDSL16 card, it has been installed, provisioned, and is in service when the wiremode is modified.

*Note: The subscriber's modem must be configured in 4-wire mode for successful 4-wire operation.*

The steps involved are:

1. Disable the card.
2. Set the card attribute WIREMODE to bonded.
3. Enable the card.

### 2.5.3 SHDSL Port Audit

With this user controllable audit, whenever a SHDSL loop experiences a degradation in quality (high Errored Seconds) it will be detected by the audit and the port will be disabled and enabled to retrain the link.

*Note: To change the level, the port must be disabled.*

There are three levels of audit, as described in [Table 2-2](#)

**TABLE 2-2 Levels of Testing for the Loop Audit**

Level	Audit Activities
OFF	<p>The audit is deactivated, SHDSL link quality is not monitored, automatic port retrains are not performed (e.g., due to loss of connection). The line must be manually retrained via disable port/enable port.</p> <p style="text-align: center;"><b>Note: This setting is for test purposes only.</b></p>
LOW	<p>The port is monitored for Data type applications. For SHDSL, this is the <b>default</b> setting. The SHDSL port will be monitored for catastrophic events such as “loss of link” and bit error rates greater than allowed under TARGETSNRMARGIN. The port will automatically retrain due to such events, and a Port Quality Retrain log is produced.</p>
MEDIUM	<p style="text-align: center;">In addition to LOW:</p> <p>The SHDSL port will be monitored for bit error rates (approx. 10<sup>-9</sup> bit errors) that affect services such as video. For SHDSL, this would not normally be used.</p>
HIGH	<p style="text-align: center;">In addition to MED:</p> <p>The SHDSL port will be aggressively monitored for bit error rates (approx. 10<sup>-10</sup> bit errors) that effect services such as video. For SHDSL, this would not normally be used.</p>

## 2.5.4 SHDSL RMON Statistics

### 2.5.4.1 STU-C/STU-R

Certain line statistics and messages are designated STU-C or STU-R. From the SHDSL16 interface/port perspective:

- STU-C - Statistics gathered on the subscriber-facing side of the SHDSL link. The statistics are collected by the MAP based on data from the modem
- STU-R - Statistics gathered from the subscriber's modem on the network side of the link. The statistics are generated on the modem based on data from the MAP.

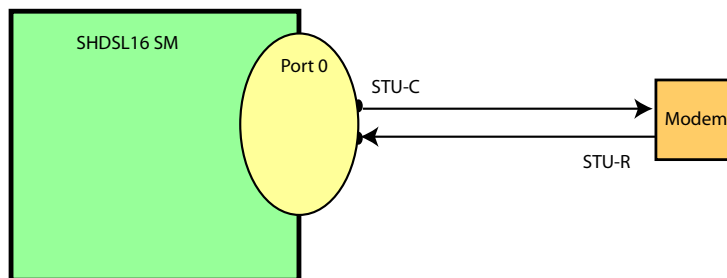

FIGURE 2-5 STU-C and STU-R

## 2.5.5 SHDSL PMON

Table 2-3 lists the PMON statistics supported by the Telesyn for SHDSL and how these should be set.

TABLE 2-3 SHDSL (PMON) Statistics

Statistic	Value	Engineering Rules for Value
hds12Shds1EndpointThreshLOSWS	0-900	
hds12Shds1EndpointThreshCRCnomalies	0-900	
hds12Shds1EndpointThreshES	0-900	
hds12Shds1PerfSESThresh	0-900	
hds12Shds1EndpointThreshUAS	0-900	

## 3. Optimizing Video Services

---

### 3.1 Overview

Video service can be configured using either:

- **ADSL** - This uses the ADSL technology/protocol at the lower protocol layer level that is transported over Ethernet. A typical configuration involves using an ADSL modem at the premises and an ADSL card at the Telesyn.
- **Ethernet** - This uses ethernet directly. A typical configuration involves using an Residential Gateway (RG) at the premises and an Ethernet card (FE or FX) at the Telesyn.

*Note: These are example configurations: refer to Section 7 for examples that employ multiple services.*

---

### 3.2 Video Services provided by ADSL

#### 3.2.1 Overview

[Figure 3-1](#) shows the basic Telesyn ADSL product configuration. It shows the customer interface in more detail and shows how video services are configured. System components include the ADSL8S, ADSL16, ADSL16B, and ADSL24 cards.

Since some subscribers may have more than one Set Top Box (STB) at their residence, the ADSL interface can support more than one STB, each needing to support a separate channel. Moreover, one STB may need to support two video channels at once (such as picture within a picture).

*Note: [Figure 3-1](#) shows two STBs attached to the ADSL interface. The general configuration rule is that each ADSL interface can support up to three STBs, and the ADSL16 card can support up to 24 STBs. Details on these rules are provided later in this section.*

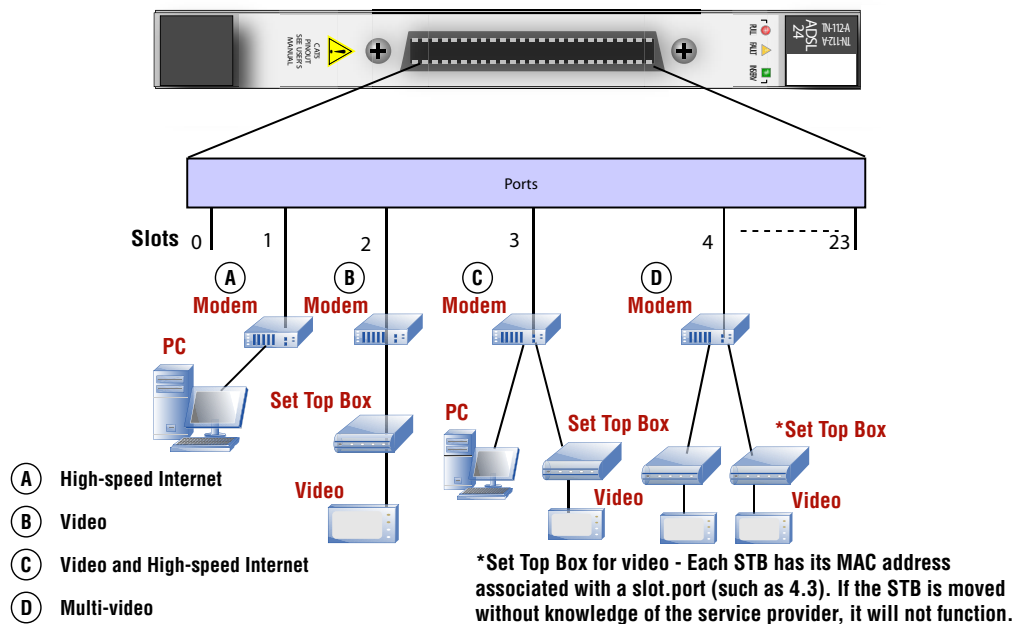

FIGURE 3-1 Example Telesyn product Configuration with Video using ADSL Modem

## 3.2.2 Technology

### 3.2.2.1 Standards

Standard	Compliance	Notes
GLITE - G.992.2	Y	N/A
GDMT - G.992.1	Y	N/A
T1413 - ANSI T1.413	Y	N/A
ADSL2+ (GSPAN) - G.span	Y	Only if running release 4.0 or earlier version software load in the ADSL card.
ADSL2 - G.992.3	Y	N/A
ADSL2+ - G.992.5	Y	N/A
READSL2 - G.992.3 Annex L	Y	N/A

### 3.2.2.2 Telesyn Implementation

In most cases, the initial configuration of the Telesyn will have at least one ADSL16 or ADSL8S card. These cards can be either ANNEX A or ANNEX B versions.

The ADSL2+ mode is a new, evolving specification for ADSL (G.992) that enables higher downstream bandwidth, based on ITU G.992.5. ADSL8S and ADSL16 Annex A hardware currently in the field will support the ADSL2+ mode using the new software.

## 3.2.3 Features

Following are the MAP and SM features that ADSL supports. See the Telesyn User Guide for information on provisioning these features.

**TABLE 3-1 Feature Interactions for ADSL Video Service**

Feature	Supported?	Notes
<b>Data Service</b>		
(VLAN)	Y	
(UFO)	Y (VLAN based)	
IGMPv2 - IGMP Snooping	Y	Needed to Support Set Top Box (STB) Mobility Feature.
HVLAN	N	

TABLE 3-1 Feature Interactions for ADSL Video Service (Continued)

Feature	Supported?	Notes
VLAN Translation	N	
Multicast channels	Y	
MAC Limiting	Y	
MAC Configuration	Y	
DHCP Relay	Y	
<b>Link Recovery</b>		
(STP)	Y	
(RSTP)	Y	
(LAG - Static)	Y	
EPSR	Y	
<b>QOS Classifier</b>		
Ethernet format	Y	
IP Protocol	Y	
IP Source	Y	
IP Destination	Y	
LSAP	Y	
MAC Source	Y	
MAC Dest.	Y	
Layer 2 Protocol	Y	
TCP Port Source	Y	
TCP Port Dest.	Y	
UDP Port Source	Y	
UDP Port Dest.	Y	
VID	Y	
InnerVID	N	
Priority	N	
IP TOS	N	
IP DSCP	N	
TCP Flags	N	
VID Priority	N	
<b>Traffic Management</b>		
VLAN - VC Mapping	Y	

TABLE 3-1 Feature Interactions for ADSL Video Service (Continued)

Feature	Supported?	Notes
IP Filtering	Y	
ARP Filtering	Y	
MAC Limiting	Y	
Remarking	N	
Ingress Metering/Policing	Y	
Queue Mapping	Y	
Egress Rate Limiting	N	
No. of Queues	8	
ACL	Y	

### 3.2.4 Network Engineering

The following rules should be followed when determining the number of set top boxes to provision on a port.

#### 3.2.4.1 ANNEX A and ANNEX B ADSL cards

ADSL cards come in two version, ANNEX-A and ANNEX-B. The Annex A ADSL card provides service to ports as described in ITU-T Recommendation G.992.

The Annex-B card has the same card type (ADSL16) but a different model number, *ADSL16B*. Annex B allows ISDN Basic Rate Access and ADSL services to co-exist over the same subscriber line. GDMT and AUTO are supported for Annex B, but the new ADSL2+ mode (as well as T1.413 and GLITE) is not supported for Annex B. There is no version of ADSL8S that supports Annex B.

**Note:** *Separate software loads files are used for ANNEX A and ANNEX B ADSL cards.*

For information on hardware and components extending from the Telesyn system to the subscriber, see the **Telesyn Wiring Guide**.

#### 3.2.4.2 Engineering of Set Top Boxes per ADSL Card and Port

Although the provisioning below specifies the ADSL16, it would be similar for the ADSL8S and ADSL24.

##### 3.2.4.2.1 Maximum Number of STBs per Individual ADSL Port

There is a finite amount of bandwidth available on an ADSL16 line, so there are limiting factors to the number of set top boxes that can be supported on any individual line. These factors are based on:

- the maximum bandwidth of the video streams
- overhead for transmitting over ADSL16

- bandwidth for Electronic Programming Guide (EPG) and emergency action channels
- bandwidth for data.

### Maximum Number of STBs per Port Based on Minimum Downstream Rate Supported - Formula

The following formula can be used to determine how many set tops can be supported on a given line:

min downstream rate = ((1+ATM Overhead)\*(Total Minimum Encoded Stream+Guaranteed Data Rate+(Voice BW\*Number of Phones))\*Number of STBs Maximum Number of STBs per Port Based on Minimum Downstream Rate Supported

For example, with an ATM Overhead of .13, if an encoder is creating video at a combined 3.5Mbps with an EPG channel of 360 Kbps, while using 2 set top boxes and guaranteeing 128K of Internet traffic, the result is:

$$(1.13*(3498 \text{ Kbps} + 256 \text{ Kbps} + (0)))*2$$

Take the result and round up to the nearest multiple of 32kbps for the minimum train rate. This result of rounding up should be identified as the Minimum Downstream Rate. In this example then, the actual value to use is 8512 Kbps.

In this example this rate is required to serve (2) STBs and the required internet connection speed. Any loop that can not consistently and reliably train to at least this value cannot support 2 STBs.

*Note: Refer to [Table 3-2](#) for a spreadsheet being used to capture these values, notes, and calculations.*

#### 3.2.4.2.2 Maximum Number of STBs per ADSL service module

Each SM in the Telesyn product is serviced by a 100Meg Ethernet connection to the central fabric controller (CFC) card. This 100Meg connection rate is completely independent of the rate that any given ADSL loop on the ADSL trains up.

Operational rules must be put into place to assure that there is always enough bandwidth available to provide video to all subscribers (100% non-blocking).

To stay below this limit the operator must assure that the total number of STBs connected to a single ADSL SM is less than the engineered maximum.

*Note: The 7000 product line can limit the number of multicast streams that are allowed on a given ADSL16 card, preventing any deterioration of video quality by preventing additional channels to be joined once the card's capacity has been reached.*

#### Maximum Number of STBs per ADSL16 Card Based on Minimum Downstream Rate Supported - Formula

The calculation is:

Max # of STBs allowed on an ADSL16 = int(100Meg / ([Maximum burst rate of any multicast channel]+(Data allowance)))



Some Video encoders produce inherently bursty data streams, particularly those which attempt to rate-limit digital satellite channels. This must be accounted for in the calculations by assuming that all STBs on the ADSL16 could be watching a different “bursty” channel. Again, the user must assume a 100% non-blocking engineering rule for bandwidth in order to avoid video disruption for the customer.

### **Maximum Number of STBs per ADSL16 Card Based on Minimum Downstream Rate Supported - Example**

For example, if it is found through network inspection at the head-end that the maximum burst rate on the combined audio/video channels is 4Mb/sec., and .5Mb is requested for minimum internet connection for the subscribers grouped on the SM. The calculation is:

$$\text{Int}(100\text{Mb}/(4.0\text{Mb} + .5\text{Mb})) = 24 \text{ STBs per ADSL16}$$

#### **3.2.4.2.3 Minimum and Maximum Downstream Rate Calculations per System**

When an ADSL16 loop trains to a particular data rate the environmental factors *at the moment* may cause it to train lower or higher than normal. Examples would include lightning storms.

- Training too low may mean that the loop won't provide enough bandwidth for the number of STBs attached, causing video disruption.
- Some modems have a tendency to train higher than what can be sustained over time, which may lead to a higher number of errored seconds than normal, which can also cause video disruption.

There is also an error correction advantage in setting a maximum train rate which is lower than the actual maximum a loop can support. In such a case the ADSL16 loop can take advantage of excess bandwidth to correct for noise on the loop. (Note: This requires bitswapping to be enabled in the ADSL16 modem).

**It is recommended that a system-wide minimum and maximum train rate be set for all loops.** The numbers used here would be for most subscribers, typically 0-10000 ft., which can expect to reach train rates to support two STBs.

For longer loops, or loops with interferers on them which prevent training to the Minimum Downstream Rate, a second training profile can be applied based on a single STB. In other words, if a loop does not train up to the recommended minimum downstream rate, then it can only support one STB.

The formula for the Minimum Downstream Rate is the same as in [Table 3-2](#). As part of the installation process the operator should verify that a loop can normally reach the minimum downstream rate without issue. In event of a poor retrain in the future (example: ADSL16 retrain during a lightning burst) the system will automatically attempt to recover by retraining the loop until the minimum is reached.

### 3.2.4.2.4 Example spreadsheet for Calculating Minimum Downstream Rate

The ADSL16 loop calculations are shown in [Table 3-2](#):

**TABLE 3-2 Calculating ADSL16 Loop Values**

Service	Attribute (Used in Calculations)	Value	Notes
Video	Encoder Video Rate	2,900,000 bps	Configurable in the encoder
	Total Encoder Audio Rate	192,000 bps	Configurable in the encoder
	Encoder Overhead Rate *	307,320 bps	Video PID 0 PAT + Video PID 100 PMT
	Video Packet Payload Size	10,528 bits	Configurable in the encoder
	IP Frame Overhead	336 bits	
	Total IP Frame Overhead Rate	98,681 bps	$((\text{Encoder Video Rate} + \text{Total Encoder Audio Rate}) / \text{Video Packet Payload Size}) * \text{IP Frame Overhead}$
	Number of STBs	2	
	Video Burst Factor	5%	Percentage the video bursts above encoded rate
	EPG Rate	40,000 bps	Configurable in the Middleware
Data	Guaranteed Rate	256,000 bps	
	Maximum Possible when video rate is not bursting to maximum & no EPG transfer	605,200 bps	$\text{EPG Rate} + \text{Guaranteed Rate} + (\text{Number of STB} * ((\text{Encoder Video Rate} + \text{Total Encoder Audio Rate}) * (1 + \text{Video Burst factor} / 100)) - (\text{Encoder Video Rate} + \text{Total Encoder Audio Rate}))$
Voice	BW per phone		
	Number of phones		

**TABLE 3-2 Calculating ADSL16 Loop Values (Continued)**

Service	Attribute (Used in Calculations)	Value	Notes
Totals	Maximum Total Video Rate	7,385,802 bps	$((\text{Video Rate} + \text{Audio Rate} + \text{Encoder Overhead Rate} + \text{IP Frame Overhead Rate}) * (1 + \text{Video Burst Factor} / 100)) * \text{Number of STB} + \text{EPG Rate}$
	Minimum Total Video Rate	6,996,002 bps	$(\text{Video Rate} + \text{Audio Rate} + \text{Encoder Overhead Rate} + \text{IP Frame Overhead Rate}) * \text{Number of STB}$
	Total Voice Rate	0 bps	
	Maximum Data Burst Rate	605,200 bps	Maximum Possible when video rate is not bursting to maximum & no EPG transfer
	Minimum ADSL16 Downstream Rate	8,484,042 bps	$((1 + \text{ATM Overhead}) * (\text{Total Minimum Encoded Stream} + \text{Guaranteed Data Rate} + (\text{Voice BW} * \text{Number of Phones}))) * \text{Number of STBs}$
	Port Mindown provisioned Rate	8,512,000 bps	= CEILING(k,32000)
	* Encoder Overhead =		
	Video PID 0 PAT (Program Association Table)	153,660	Constant
	Video PID 100 PMT (Program Map Tables)	153,660	Constant
	Total Encoded Stream (Min)	3,498,001	$((\text{Encoder Video Rate} + \text{Total Encoder Audio Rate}) * (1 + (\text{IP Frame Overhead} / \text{Video Packet Payload Size}))) + \text{Encoder Overhead Rate}$
	Total Encoded Stream (Max)	3,657,535	$((\text{Encoder Video Rate} + \text{Total Encoder Audio Rate}) * (1 + \text{Video Burst factor} / 100)) * (1 + (\text{IP Frame Overhead} / \text{Video Packet Payload Size}))) + \text{Encoder Overhead Rate}$

### 3.2.4.3 Engineering of STBs for the ADSL24

Calculations for the maximum number of STBs per port are the same for the ADSL24 SM as those discussed above for the ADSL16 and ADSL8S. Refer to [Figure 3.2.4.2](#) for more information. 3 STBs per ADSL24 port is the norm.

### 3.2.4.4 ADSL IGMP Video Configuration

For each ADSL interface, the following can be configured for the specified Telesyn:

- Three STB with Five streams per STB
- One channel change per STB per second

## 3.2.5 Software Engineering

### 3.2.5.1 Provisioning for ADSL Ports

Once an interface is provisioned and enabled, the ADSL Loop Quality Audit is activated to ensure the ADSL loop can support what is provisioned (refer to [3.2.5.2](#)).

[Table 3-3](#) lists the most important port attributes for video service.

**TABLE 3-3 Port Attributes for Video Service**

Attribute	Provisioning Guideline	Reference
Customer ID	To identify a customer loop, a description can be assigned to the ADSL port	See the <b>Telesyn User Guide</b> , section <b>Provisioning Network, Service, and Control Modules</b> , subsection <b>SM Category Attributes</b> .
Minimum Downstream-Rate	The Minimum Downstream Rate is the minimum bandwidth downstream necessary to support the services (video service to one or two STBs).	See <a href="#">Table 3-4</a>
Maximum DownStream-Rate	The Maximum Downstream Rate should be set lower than the actual maximum the ADSL loop can support, in order to use the excess bandwidth to correct for noise on the loop.	See <a href="#">Table 3-4</a>
Set Top Box MAC Addresses	Each IGMP device must have a unique MAC address associated with it. Provisioning the STB MAC address is required to prevent theft of service.	<a href="#">3.2.4.2.1</a>

**TABLE 3-3 Port Attributes for Video Service**

<b>Attribute</b>	<b>Provisioning Guideline</b>	<b>Reference</b>
Allowed IP Address Ranges	The IP Filtering feature allows upstream filtering of subscriber devices (STBs and PCs for example) based on an IP address or range of IP addresses. If this is not configured correctly, a subscriber may not be able to receive service.	See the <b>Telesyn User Guide</b> , section <b>Traffic Management</b> .
MAC Limiting	When the learning limit is reached, all frames are dropped, including Broadcast and Multicast frames.	See the <b>Telesyn User Guide</b> , section <b>IGMP</b> , subsection <b>MAC Limiting</b> .

TABLE 3-4 Tasks for Providing Quality ADSL Video Service

Task	Attribute	Telesyn NMS Interface	Telesyn (CLI) Interface
Port Provisioning	Customer ID	<p>The Port Management Form is accessed by highlighting a Telesyn 7000/9000 icon and following these steps:</p> <ol style="list-style-type: none"> <li>1. Select <i>Provision -&gt; Port Management</i></li> <li>2. In the <b>Port Management</b> form, select a port and then <b>Provision</b>.</li> <li>3. In the <b>Provision Port</b> form fill in port attributes, including Customer ID.</li> </ol> <p>The user can also modify the ID using the <b>ADSL Port Management</b> form.</p> <p>Refer to Section 5 of the NMS Administration Guide for details.</p>	Enter a DESCRIPTION value in the <b>SET INTERFACE</b> command.
	Minimum Downstream Rate	The same form as the Customer ID.	<p>Enter a MINDOWN-STREAMRATE value in the <b>SET PORT</b> command.</p> <p>Refer to See the <b>Telesyn User Guide</b>, section <b>Provisioning Network, Service, and Control Modules</b>, subsection <b>SM Category Attributes</b>.</p>
	Maximum Downstream Rate	The same form as the Customer ID.	<p>Enter a MAXDOWN-STREAMRATE value in the <b>SET PORT</b> command.</p> <p>Refer to See the <b>Telesyn User Guide</b>, section <b>Provisioning Network, Service, and Control Modules</b>, subsection <b>SM Category Attributes</b>.</p>
	STB Mac Addresses	The same form as the Customer ID.	Associate a MACADDRESS with a port.
	IP Filter Ranges	The same form as the Customer ID.	Set the IP range for each port..

TABLE 3-4 Tasks for Providing Quality ADSL Video Service (Continued)

Task	Attribute	Telesyn NMS Interface	Telesyn (CLI) Interface
Port Monitoring	Errored Seconds (ES)	<p>In the Network Inventory node, select Ports</p> <p>Right Click a Customer ID and select <b>View Port</b></p> <p>In the ADSL <b>Port Management</b> form, select the ADSL Statistics tab and <b>Enable Statistics</b> to activate.</p> <p>In the <b>ADSL Port Management</b> form, select the <b>ADSL Stats Graph</b> tab and select the ESs statistics to plot a graph.</p> <p>Refer to Section 5 of the NMS Administration Guide for details.</p>	<p>View the ESs with the <code>SHOW PORT PMON</code> command.</p> <p>Select a threshold for the ESs using the <code>SET INTERFACE=(SLOT.PORT) PMONALERT ATUCES THRESHOLD</code></p>
	Fault Counters	<p>Access the <b>ADSL Port Management</b> form.</p> <p>Select the <b>ADSL Statistics</b> tab to view and reset.</p> <p>Refer to Section 5 of the NMS Administration Guide for details.</p>	<p>View the counters with <code>SHOW INTERFACE &lt;interface name&gt; FAULTCOUNT</code> command.</p> <p>Refer to <a href="#">3.2.5.3</a>.</p>
	Quality of Service (QOS) Counters	<p>Access <b>ADSL Port Management</b> form.</p> <p>In the ADSL Port Management form, select the <b>ADSL Statistics</b> tab to view and reset.</p> <p>Refer to Section 5 of the NMS Administration Guide for details.</p>	<p>View the counters with <code>SHOW INTERFACE &lt;interface name&gt; QUEUECOUNT STATUS</code> command</p> <p>Refer to <a href="#">3.2.5.3</a>.</p>
System Monitoring	Control Module Counters	Not currently implemented.	<p>View the counters with <code>SHOW SWITCH COUNTER</code> command</p> <p>Refer to See the <b>Telesyn User Guide</b>, section <b>Implementing Telesyn™ 7000 Features</b>, subsection <b>System Counters</b>.</p>
Logs	Viewing Logs	<p>Access <b>ADSL Port Management</b> form.</p> <p>In the ADSL Port Management form, select the <b>ADSL Port Log</b> tab to view.</p> <p>Refer to Section 5 of the NMS Administration Guide for details.</p>	<p>View ADSL logs.</p> <p>Refer to <a href="#">3.2.6.1</a>.</p>

### 3.2.5.2 ADSL Loop Quality Audit

Without this audit, an ADSL port would detect a Loss of Link and would try to re-enable the link. In applications such as video, however, a degradation (rather than a loss) of the loop quality could still make the video unusable.

With this audit, whenever an ADSL loop experiences a degradation in quality (high Errored Seconds) it will be detected by the audit and the port will be disabled and enabled to retrain the link.

#### 3.2.5.2.1 Setting the Level of the Audit

*Note: To change the level, the port must be disabled.*

There are three levels of audit, as described here.

**TABLE 3-5 Levels of Testing for the Loop Audit**

Level	Audit Activities
OFF	This setting is for test purposes only. The audit is deactivated, ADSL link quality is not monitored, automatic port retrains are not performed (e.g., due to loss of connection). The line must be manually retrained via disable port/enable port. <b>Note: This setting is for test purposes only.</b>
LOW	The ADSL port will be monitored for catastrophic events such as “loss of link” and bit error rates greater than allowed under TARGETSNRMARGIN. The port will automatically retrain due to such events, and a Port Quality Retrain log is produced.
MEDIUM	In addition to LOW:  The ADSL port will be monitored for bit error rates that effect video quality. The port will be automatically retrained, and a Port Quality Retrain alarm and log are produced.
HIGH	In addition to MED:  The ADSL port will be aggressively monitored for bit error rates that effect video quality. The port will be automatically retrained, and a Port Quality Retrain alarm and log are produced.

### 3.2.5.3 ADSL Interface Monitoring

The following thresholds and counters are especially important to monitor the port for problems or potential problems.

#### 3.2.5.3.1 Errored Seconds

The Errored Seconds statistic is monitored by the Loop Quality Audit. When the ES is being monitored and the audit has had to retrain the ADSL port, the viewing of the statistic should show the ES rate increasing for a period and then returning to an acceptable number as a result of the retraining of the port.



In addition to the monitoring of ES that is done by the audit, ES should be monitored by the network engineer. A threshold should be set at 100 ES/hour to monitor both the quality of the loop and the performance of the audit. This threshold is higher than what the audit provides for the following reasons:

- If the higher threshold is passed and its related log is produced, there is a problem on the port that the audit cannot resolve (such as permanent physical impairments), and further troubleshooting is required.
- The performance of the audit can be monitored, and in the unlikely event the audit was not running, the higher threshold would catch the rise in ESs and the log would indicate when it occurred.

### 3.2.5.3.2 Fault Counters

These counters increment for Link Fault events that are logged, and increment for these faults at the ADSL port as well as the upstream port.

Table 3-6 describes the counters.

**TABLE 3-6 Port Counter Faults (SHOW PORT COUNTER FAULT)**

Counter	Meaning
Loss of Link	Keeps track of the number of times a loss of link condition occurred on the given interface. The counter will wrap
Loss of Signal	Keeps track of the number of times a loss of signal condition occurred on the given interface. The counter will wrap
Loss of Frame	Keeps track of the number of times a loss of frame condition occurred on the given interface
Peer Not Present	Keeps track of the number of times the modem goes offline.
(Reset)	This flag can be set to true(1) to reset all fault counters to zero. The flag will set automatically to zero so that it can be set to true to reset again

### 3.2.5.3.3 QOS Counters

There are four/eight queues for traffic management:

To track the bandwidth usage for these queues, there is a set of counters for sent and dropped packets for each queue.

A high priority dropped packets condition indicates the amount of video traffic being pulled by the subscriber is greater than the available bandwidth. The subscriber can cause this condition by using a PC client to join a video multicast channel causing more multicast channels to be sent to the subscriber than the downstream rate can support. The Service Provider can cause this by providing the customer too many STBs which exceed the engineering rules listed in [3.2.4.2](#).

A low priority dropped packets condition indicates the amount of data being downloaded to the subscriber exceeds the amount allocated. Again, refer to [3.2.4.2](#).

Table 3-7 describes the counters.

**TABLE 3-7 Port Counter Quality of Service (SHOW PORT COUNTER QUEUE)**

Counter	Meaning	Possible Cause/Notes
High Priority Dropped Packets	keeps track of the number of Dropped High Priority Packets on an ADSL interface (port)	The port is set at 4 meg, and the subscriber has two 4-meg for video, which would drop one-half multicast (video) traffic
High Priority Sent Packets	keeps track of the number of Sent High Priority Packets on an ADSL interface (port)	
Low Priority Dropped Packets	keeps track of the number of Dropped Low Priority Packets on an ADSL interface (port)	All bandwidth is being used for high priority traffic, and low priority (internet) is dropping packets. IP will try to resend, but if not enough bandwidth may never get through
Low Priority Sent Packets	keeps track of the number of Sent Low Priority Packets on an ADSL interface (port)	
(Reset)	This flag can be set to true(1) to reset all 4 QOS counters for the given port (identified by port) to zero. The flag will reset automatically to zero so that it can be set to true to reset again	

### 3.2.5.4 ADSL RMON Statistics

The following table details RMON statistics for ADSL cards. For more information, see the **Telesyn User Guide**, subsection **Monitoring Performance Management**.

**TABLE 3-8 RMON Statistics**

Statistic	Service Module	
	ADSL8S/16	ADSL24
<b>IF MIB</b>		
ifInOctets	RX	RX
ifInUcastPkts	RX	RX
ifInNUcastPkts	RX	RX
ifInDiscards	RX	RX
ifInErrors	RX	RX
ifInUnknownProtos	RX	RX

TABLE 3-8 RMON Statistics (Continued)

Statistic	Service Module	
	ADSL8S/16	ADSL24
ifOutOctets	TX	TX
ifOutUcastPkts	TX	TX
ifOutNUcastPkts	TX	TX
ifOutDiscards	TX	TX
ifOutErrors	TX	TX
<b>Regular Counts</b>		
etherStatsDropEvents	Always 0	RX
etherStatsBroadcastPkts	TX	Sum of RX & TX
etherStatsMulticastPkts	TX	Sum of RX & TX
etherStatsUndersizePkts	Always 0	RX
etherStatsFragments	Always 0	RX
etherStatsPkts64Octets	Always 0	Sum of RX & TX
etherStatsPkts65to127Octets	Always 0	Sum of RX & TX
etherStatsPkts128to255Octets	Always 0	Sum of RX & TX
etherStatsPkts256to511Octets	Always 0	Sum of RX & TX
etherStatsPkts512to1023Octets	Always 0	Sum of RX & TX
etherStatsPkts1024to1518Octets	Always 0	Sum of RX & TX
etherStatsOversizePkts	Always 0	RX
etherStatsJabbers	Always 0	RX
etherStatsOctets	TX	Sum of RX & TX
etherStatsPkts	TX	Sum of RX & TX
etherStatsCollisions	Always 0	TX
etherStatsCRCAlignErrors	Always 0	RX
<b>High Capacity</b>		
etherStatsDropEvents	Always 0	RX
etherStatsBroadcastPkts	TX	Sum of RX & TX
etherStatsMulticastPkts	TX	Sum of RX & TX
etherStatsUndersizePkts	Always 0	RX
etherStatsFragments	Always 0	RX
etherStatsPkts64Octets	Always 0	Sum of RX & TX

TABLE 3-8 RMON Statistics (Continued)

Statistic	Service Module	
	ADSL8S/16	ADSL24
etherStatsPkts65to127Octets	Always 0	Sum of RX & TX
etherStatsPkts128to255Octets	Always 0	Sum of RX & TX
etherStatsPkts256to511Octets	Always 0	Sum of RX & TX
etherStatsPkts512to1023Octets	Always 0	Sum of RX & TX
etherStatsPkts1024to1518Octets	Always 0	Sum of RX & TX
etherStatsOversizePkts	Always 0	RX
etherStatsJabbers	Always 0	RX
etherStatsOctets	TX	Sum of RX & TX
etherStatsPkts	TX	Sum of RX & TX
etherStatsCollisions	Always 0	TX
etherStatsCRCAlignErrors	Always 0	RX

### 3.2.5.5 ADSL PMON Statistics

The following table lists PMON statistics for ADSL cards. For more information, see the **Telesyn User Guide**, subsection **PMON (ADSL Port) Statistics**.

TABLE 3-9 ADSL (PMON) Statistics

Statistic	Value	Description
adslAtucThresh15MinLOFs	0-900	The number of Loss of Frame Seconds encountered by an ADSL interface within any given 15 minutes performance data collection period, which causes the SNMP agent to send an adslAtucPerfLofsThreshTrap. One trap will be sent per interval per interface. A value of '0' will disable the trap and the log.
adslAtucThresh15MinLOSs	0-900	The number of Loss of Signal Seconds encountered by an ADSL interface within any given 15 minutes performance data collection period, which causes the SNMP agent to send an adslAtucPerfLossThreshTrap. One trap will be sent per interval per interface. A value of '0' will disable the trap and the log.
adslAtucThresh15MinLOLs	0-900	The number of Loss of Link Seconds encountered by an ADSL interface within any given 15 minutes performance data collection period, which causes the SNMP agent to send an adslAtucPerfLolsThreshTrap. One trap will be sent per interval per interface. A value of '0' will disable the trap and the log.

TABLE 3-9 ADSL (PMON) Statistics (Continued)

Statistic	Value	Description
adslAtucThresh15MinLPRs	0-900	The number of Loss of Power Seconds encountered by an ADSL interface within any given 15 minutes performance data collection period, which causes the SNMP agent to send an adslAtucPerfLprsThreshTrap. One trap will be sent per interval per interface. A value of `0` will disable the trap and the log will disable the trap and the log.
adslAtucThresh15MinESs	0-900	The number of Errored Seconds encountered by an ADSL interface within any given 15 minutes performance data collection period, which causes the SNMP agent to send an adslAtucPerfESsThreshTrap. One trap will be sent per interval per interface. A value of `0` will disable the trap and the log.
adslAtucInitFailureTrapEnable	1-2	Enables and disables the InitFailureTrap. This object is defaulted disabled (value 2), otherwise enabled (value 1). Note that the system tracks the number of occurrences in 15-minute and 24-hour intervals.
adslAturThresh15MinLOFs	0-900	The number of Loss of Frame Seconds encountered by an ADSL interface within any given 15 minutes performance data collection period, which causes the SNMP agent to send an adslAturPerfLofsThreshTrap. One trap will be sent per interval per interface. A value of `0` will disable the trap and the log.
adslAturThresh15MinLOSs	0-900	The number of Loss of Signal Seconds encountered by an ADSL interface within any given 15 minutes performance data collection period, which causes the SNMP agent to send an adslAturPerfLossThreshTrap. One trap will be sent per interval per interface. A value of `0` will disable the trap and the log.
adslAturThresh15MinLPRs	0-900	The number of Loss of Power Seconds encountered by an ADSL interface within any given 15 minutes performance data collection period, which causes the SNMP agent to send an adslAturPerfLprsThreshTrap. One trap will be sent per interval per interface. A value of `0` will disable the trap and the log.  This statistic is derived from the “dying gasp” message sent by the atur when power is removed from the modem.
adslAturThresh15MinESs	0-900	The number of Errored Seconds encountered by an ADSL interface within any given 15 minutes performance data collection period, which causes the SNMP agent to send an adslAturPerfESsThreshTrap. One trap will be sent per interval per interface. A value of `0` will disable the trap and the log.

TABLE 3-9 ADSL (PMON) Statistics (Continued)

Statistic	Value	Description
adslAtucThresh15MinSesL	0-900	The first time the value of the corresponding instance of adslAtucPerf15MinSesL reaches or exceeds this value within a given 15-minute performance data collection period, an adslAtucSesLThreshTrap notification will be generated. The value '0' will disable the notification. The default value of this object is '0'.
adslAtucThresh15MinUasl	0-900	The first time the value of the corresponding instance of adslAtucPerf15MinUasL reaches or exceeds this value within a given 15-minute performance data collection period, an adslAtucUasLThreshTrap notification will be generated. The value '0' will disable the notification. The default value of this object is '0'.
adslAturThresh15MinSesL	0-900	The first time the value of the corresponding instance of adslAturPerf15MinSesL reaches or exceeds this value within a given 15-minute performance data collection period, an adslA-turSesLThreshTrap notification will be generated. The value '0' will disable the notification. The default value of this object is '0'.
adslAtucSesLThreshTrap	0-900	Severely errored seconds-line 15-minute threshold reached
adslAtucUasLThreshTrap	0-900	Unavailable seconds-line 15-minute threshold reached.

## 3.2.6 Maintenance

### 3.2.6.1 Logs

The Telesyn User Guide lists the objects in the ATN Enterprise MIB that produce traps and therefore messages for an snmp-enabled browser or the Telesyn NMS. These conditions also produce logs and alarms, which are described below.

By analyzing these logs, customer support can resolve many issues that may be the result of an incorrect subscriber or network configuration.

### 3.2.6.2 Multicast Logs

Table 3-10 lists the log messages associated with the multicast limits in the Telesyn product.

**TABLE 3-10 Multicast Logs**

Log Message	Meaning	Action / Reference
High Water Mark per Card Exceeded	The card is coming close to the IGMP group limit. The default is 20.	No action is required, although this is a warning.
Channel Limit per Card Exceeded	The IGMP group limit per card set with the SET IGMP Snooping Card (slot) MCASTGROUPLIMIT has been exceeded. The default is 25.	There are too many devices requesting multicast channels on this card.
High Water Mark per Card Cleared	The IGMP group limit per card has dropped below the high water mark	No action is required, this is information.
MAC Limit per Port Exceeded	The maximum number of multicast devices per port has been exceeded	Contact the subscriber.
Group Limit per MAC (device) Exceeded	The subscriber device is requesting more channels than allowed.	Check for an STB malfunction and/or contact subscriber.

### 3.2.6.3 ADSL Port Logs

These are the logs associated with the ADSL Loop Quality Audit. The log messages show that the audit has found a problem and is trying to fix the problem by disabling and enabling the port to retrain the link

Figure 3-2 shows samples of the three log messages, while Table 3-11 describes the messages.

ADSL018 2003-07-30 15:26:42 4217 OTHER

Forced retrain of the port (Slot.Port:15.8) due to degradation of loop quality ("excessive" ES) above acceptable thresholds.

ADSL019 2003-07-30 15:26:42 4216 OTHER

Force retrain of the port (Slot.Port:15.8) due to the port's inability to connect (attain SHOWTIME) after X handshake attempts.

ADSL020 2003-07-30 15:26:42 4215 OTHER

Forced retrain of the port (Slot.Port:15.8) due to its connection below the configured minimum downstream rate.

**FIGURE 3-2 ADSL Port Log Examples**

**TABLE 3-11 ADSL Port Logs**

<b>Log Message</b>	<b>Meaning</b>	<b>Action / Reference</b>
Port Quality Retrain	The Errored Seconds is too high, so the ADSL port is disabled and enabled to retrain the link.	Audit will try to retrain the port to an acceptable level
Port Stuck Handshake Retrain	The physical layer connection failed, so the ADSL port is disabled and enabled to retrain the link	Audit will try to retrain the port to an acceptable level
Port Min Down Rate Retrain	The connect rate is below the provisioned minimum downstream rate, so the ADSL port will be disabled and enabled to retrain the link,	Audit will try to retrain the port to an acceptable level

### 3.2.7 Loop Length and Data Rates (Rate vs. Reach) for ADSL Modes

In release 7.0, Annex M is available, which provides a higher downstream data rate for Annex A tpe interfaces. The following figure compares the rate vs. reach for the various modes.



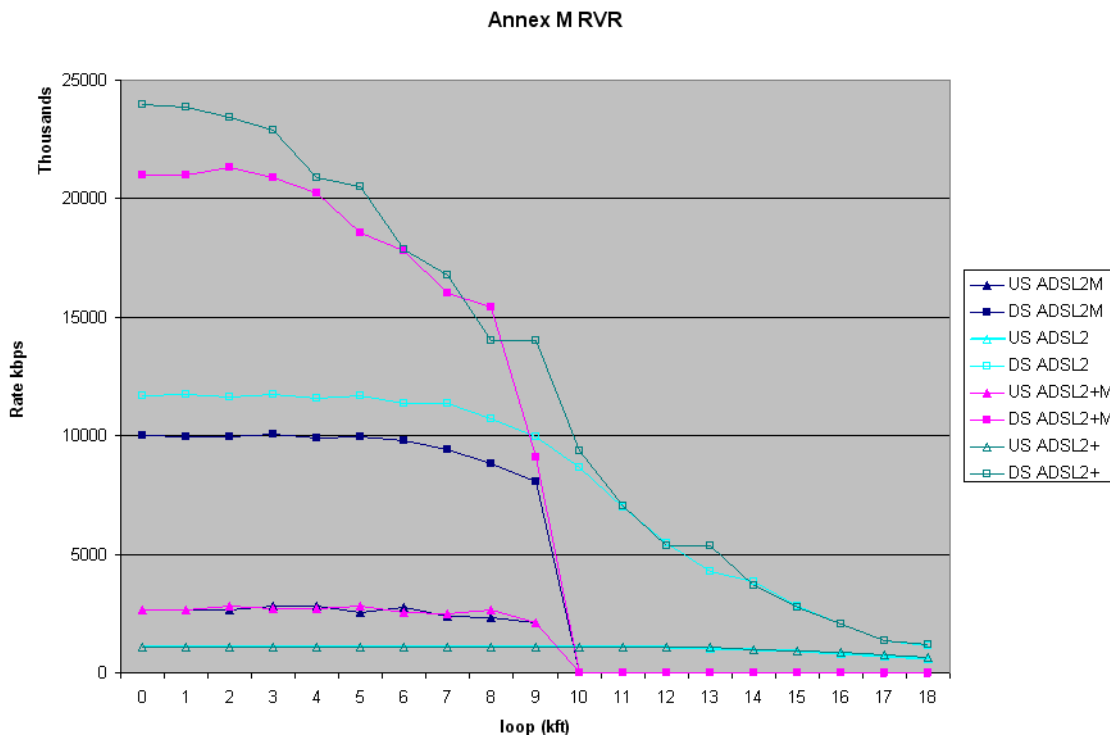

FIGURE 3-3 Rate vs Reach for ADSL modes

## 3.3 Video Services Provided by Fast Ethernet/Fiber

### 3.3.1 Overview

Figure 3-4 shows the Telesyn copper Ethernet and fiber line product configuration. It shows the customer interface and how video services are configured. System components include the FE10 and FX10 (FE and FX) cards. The residential gateway provides the fiber termination. For this example, the fiber line FX10 card is illustrated.

The interface can support more than one STB, each needing to support a separate channel.

*Note:* Figure 3-4 shows two STBs attached to the FE and FX interface. The general configuration rule is that each interface can support up to three STBs, and, for this example, the FX10 card can support up to 30 STBs. Details on these rules are provided later in this section.

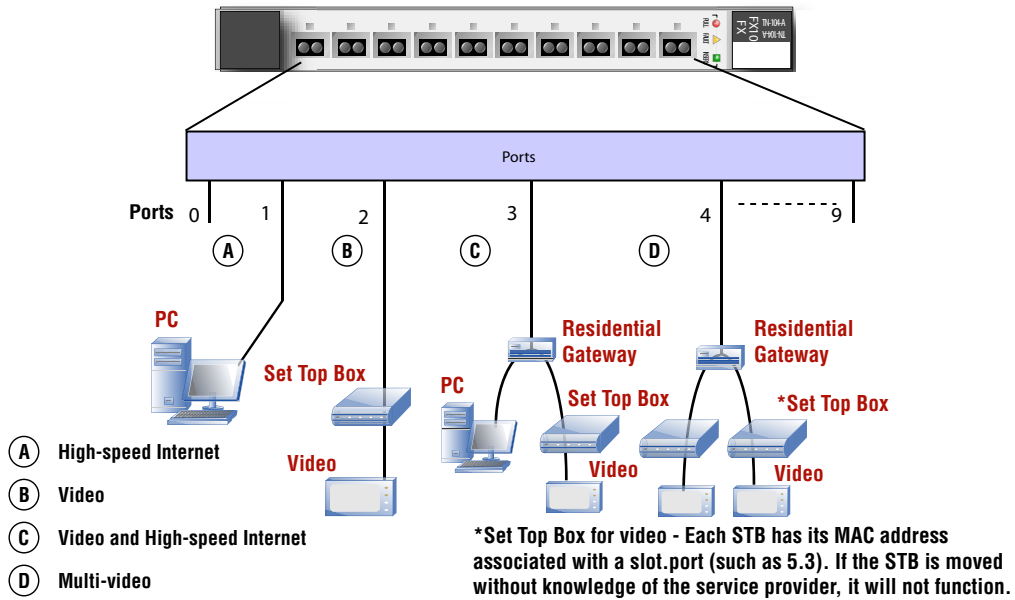

FIGURE 3-4 Example Telesyn product Configuration with Video - Fiber-based

### 3.3.2 Technology

#### 3.3.2.1 Standards

Standard	Compliance	Notes
IEEE - 802.3 -1998	Y	N/A

### 3.3.3 Features

### 3.3.4 Network Engineering

#### 3.3.4.1 STB - Fast Ethernet and Fiber-based

There is a finite number of STBs that can be supported on any fast ethernet or fiber-based line. These factors are based on:

- the maximum bandwidth of the video streams

- overhead for transmitting over the line
- bandwidth for Electronic Programming Guide (EPG) and emergency action channels
- bandwidth for data

### 3.3.4.2 FE10/FX10 IGMP Video Configuration

For each ADSL and fiber interface, the following can be configured for the specified Telesyn:

- Three STB with Five streams per STB

## 3.3.5 Software Engineering

### 3.3.5.1 Interface Provisioning for Fast Ethernet and Fiber-based Ports

Refer to Section **Provisioning Network, Service, and Control Modules** and subsection **ADSL Port** for an overview of all attributes of these interfaces.

To provide quality video service, the service provider must perform the following tasks:

1. Correctly provision the interface.
2. Monitor the interface so problems or potential problems can be noted and resolved.
3. Ensure service providers have correctly configured the equipment.
4. Check for faults with the physical connection(s) or equipment from the interface to the subscriber's equipment.

The first two tasks are directly related to provisioning the Telesyn product and are therefore covered both in this section and other sections of this Guide. Moreover, the Telesyn product helps with the other two tasks by providing features that help determine if a problem is in a component that is not directly a part of the Telesyn product.

With these features, service providers can provide more timely customer support and ensure the subscriber line is correctly configured.

Table 3-13 lists these tasks, what attributes are provisioned for these tasks, and the steps taken at either the Network Management System (NMS) or local interface (CLI) to provide values for these attributes.

**TABLE 3-12 Fast Ethernet and Fiber-based Port Attributes for Video Service**

FEPOR Attribute	FEXPORT Attribute	Provisioning Guideline	Reference
Customer ID	Customer ID	To identify a customer loop, a description can be assigned to the port	See the <b>Telesyn User Guide</b> , section <b>Provisioning Network, Service, and Control Modules</b> , subsection <b>SM Category Attributes</b> .
DUPLEX	n/a	As required for the line. The default is <b>AUTO</b> , where the mode is auto negotiated with the remote peer.	n/a
FLOWCON- TROL	FLOWCON- TROL	As required for the line. If set to <b>AUTO</b> , the port can generate and respond to pause signals with the remote peer. If set to <b>MANUAL</b> , pause is ignored and not generated, and potential for packet loss is increased.  <i>Note: On the 9000 system, if set to <b>AUTONEGOTIATE</b>, the port will respond to pause frames from a remote peer. If set to <b>ON</b>, pause is ignored and potential for packet loss is increased. <b>The 9000 chassis does not generate pause frames.</b></i>  The default value is <b>AUTONEGOTIATE</b> .	n/a
SPEED	n/a	As required for the line. The default is <b>AUTO</b> , where the speed is auto negotiated with the remote peer.	n/a
WITH	n/a	As required for the line	n/a
STB Mac Addresses	STB Mac Addresses	Each IGMP device must have a unique MAC address associated with it. Provisioning the STB MAC address is required to prevent theft of service.	

**TABLE 3-12 Fast Ethernet and Fiber-based Port Attributes for Video Service**

<b>FEXPORT Attribute</b>	<b>FEXPORT Attribute</b>	<b>Provisioning Guideline</b>	<b>Reference</b>
IP Filter Ranges	IP Filter Ranges	The IP Filtering feature allows upstream filtering of subscriber devices (STBs and PCs for example) based on an IP address or range of IP addresses. If this is not configured correctly, a subscriber may not be able to receive service.	See the <b>Telesyn User Guide</b> , section <b>Traffic Management</b> .
MAC Limiting	MAC Limiting	When the learning limit is reached, all frames are dropped, including Broadcast and Multicast frames.	See the <b>Telesyn User Guide</b> , section <b>IGMP</b> , subsection <b>MAC Limiting</b> .

TABLE 3-13 Tasks for Providing Quality Fast Ethernet and Fiber-based Video Service

Task	FEPOR Attribute	FXPOR Attribute	Telesyn NMS Interface	Telesyn 9000 (CLI) Interface
Port Provisioning	Customer ID	Customer ID	The Port Management Form is accessed by highlighting a Telesyn 9000 icon and following these steps: <ol style="list-style-type: none"> <li>1. Select <i>Provision -&gt; Port Management</i></li> <li>2. In the <b>Port Management</b> form, select a port and then <b>Provision</b>.</li> <li>3. In the <b>Provision Port</b> form fill in port attributes, including Customer ID.</li> </ol> The user can also modify the ID using the <b>Port Management</b> form. Refer to the NMS Administration Guide for details.	Enter a DESCRIPTION value in the <b>SET PORT</b> command.
	DUPLEX	n/a	Select a value.	Enter AUTONEGOTIATE, FULL, or HALF value in the <b>SET INTERFACE</b> command..
	FLOW-CONTROL	FLOW-CONTROL	Select a value.	Enter ON or OFF in the <b>SET INTERFACE</b> command.
	SPEED	n/a	Select a value.	Enter AUTONEGOTIATE, 10, or 100 in the <b>SET INTERFACE</b> command.
	WITH	n/a	Select a value.	Enter the name or identity for a LAG in the <b>SET INTERFACE</b> command.
	STB Mac Addresses	STB Mac Addresses	The same form as the Customer ID.	Associate a MACADDRESS with a port.
	IP Filter Ranges	IP Filter Ranges	The same form as the Customer ID.	Set the IP range for each port.

TABLE 3-13 Tasks for Providing Quality Fast Ethernet and Fiber-based Video Service (Continued)

Task	FEXPORT Attribute	FXPORT Attribute	Telesyn NMS Interface	Telesyn 9000 (CLI) Interface
Port Monitoring	RMON Statistics	RMON Statistics	<p>In the Network Inventory node, select Customer Ports</p> <p>Highlight a Customer ID and select <i>Customer</i> -&gt; <i>View Customer</i> Port</p> <p>In the <b>Port Management</b> form, select the Statistics tab and <b>Enable</b> to activate.</p> <p>In the <b>Port Management</b> form, select the Stats Graph tab and select the ESs statistics to plot a graph.</p> <p>Refer to Section 5 of the NMS Administration Guide for details.</p>	Set the ethernet RMONALERT using the <b>SET INTERFACE &lt;interface name&gt; RMONALERT</b> command.
	Fault Counters	Fault Counters	<p>Refer to ES row above to access Port Management form.</p> <p>In the Port Management form, select the Statistics tab to view and reset.</p> <p>Refer to Section 5 of the NMS Administration Guide for details.</p>	View the counters with <b>SHOW SHOW INTERFACE &lt;interface name&gt; FAULTCOUNT</b> command. Refer to <a href="#">3.2.5.3</a> .
Logs	Viewing Logs		<p>Refer to ES row above to access Port Management form.</p> <p>In the Port Management form, select the Port Log tab to view.</p> <p>Refer to Section 5 of the NMS Administration Guide for details.</p>	View RMON logs. Refer to <a href="#">3.2.6.1</a> .

### 3.3.5.2 Performance Data monitoring & Alarm thresholds

#### 3.3.5.2.1 RMON Statistics

The following table details RMON statistics for FE10 and FX10 cards.

**TABLE 3-14 RMON Statistics**

Statistic	Service Module
	FE10/FX10
<b>IF MIB</b>	
ifInOctets	RX
ifInUcastPkts	RX
ifInNUcastPkts	RX
ifInDiscards	RX
ifInErrors	RX
ifInUnknownProtos	RX
ifOutOctets	TX
ifOutUcastPkts	TX
ifOutNUcastPkts	TX
ifOutDiscards	TX
ifOutErrors	TX
<b>Regular Counts</b>	
etherStatsDropEvents	RX
etherStatsBroadcastPkts	Sum of RX & TX
etherStatsMulticastPkts	Sum of RX & TX
etherStatsUndersizePkts	RX
etherStatsFragments	RX
etherStatsPkts64Octets	Sum of RX & TX
etherStatsPkts65to127Octets	Sum of RX & TX
etherStatsPkts128to255Octets	Sum of RX & TX
etherStatsPkts256to511Octets	Sum of RX & TX
etherStatsPkts512to1023Octets	Sum of RX & TX
etherStatsPkts1024to1518Octets	Sum of RX & TX
etherStatsOversizePkts	RX
etherStatsJabbers	RX



TABLE 3-14 RMON Statistics (Continued)

Statistic	Service Module
	<b>FE10/FX10</b>
etherStatsOctets	Sum of RX & TX
etherStatsPkts	Sum of RX & TX
etherStatsCollisions	TX
etherStatsCRCAlignErrors	RX
<b>High Capacity</b>	
etherStatsDropEvents	RX
etherStatsBroadcastPkts	Sum of RX & TX
etherStatsMulticastPkts	Sum of RX & TX
etherStatsUndersizePkts	RX
etherStatsFragments	RX
etherStatsPkts64Octets	Sum of RX & TX
etherStatsPkts65to127Octets	Sum of RX & TX
etherStatsPkts128to255Octets	Sum of RX & TX
etherStatsPkts256to511Octets	Sum of RX & TX
etherStatsPkts512to1023Octets	Sum of RX & TX
etherStatsPkts1024to1518Octets	Sum of RX & TX
etherStatsOversizePkts	RX
etherStatsJabbers	RX
etherStatsOctets	Sum of RX & TX
etherStatsPkts	Sum of RX & TX
etherStatsCollisions	TX
etherStatsCRCAlignErrors	RX

Engineering Recommendations are provided for guidance on the maintenance and monitoring of the network. The goal is to improve the video quality and maintainability by providing enhanced management methods. These recommendations are meant to improve network operation and management, but may not be applicable to all implementations.

Thresholds can be set for the RMON statistics. Separate thresholds should be set as follows in this system response to the SET INTERFACE command on a FE port (same for a FX port):

**TABLE 3-15 RMON Statistics**

<b>Statistic</b>	<b>Description</b>
BROADCAST	The total number of good packets received that were directed to the broadcast address. Note that this does not include multicast packets
COLLISIONS	The best estimate of the total number of collisions on this Ethernet segment
CRCALIGN	The total number of packets received that had a length (excluding framing bits, but including FCS octets) of between 64 and 1518 octets, inclusive, but had either a bad Frame Check Sequence (FCS) with an integral number of octets (FCS Error) or a bad FCS with a non-integral number of octets (Alignment Error).
DROPEVENTS	The total number of times packets were dropped by the NMS due to lack of resources.
FRAGMENTS	The total number of packets received that were less than 64 octets in length (excluding framing bits but including FCS octets) and had either a bad Frame Check Sequence (FCS) with an integral number of octets (FCS Error) or a bad FCS with a non-integral number of octets (Alignment Error).
JABBERS	The total number of packets received that were longer than 1518 octets (excluding framing bits, but including FCS octets), and had either a bad Frame Check Sequence (FCS) with an integral number of octets (FCS Error) or a bad FCS with a non-integral number of octets (Alignment Error).
MULTICAST	The total number of good packets received that were directed to a multicast address. Note that this number does not include packets directed to the broadcast
OCTETS	The total number of octets of data (including those in bad packets) received on the network, excluding framing bits but including Frame Check Sequence (FCS) octets.
OVERSIZE	The total number of packets received that were longer than 1518 octets (excluding framing bits, but including FCS octets) and were otherwise well formed.
PACKETS	The total number of octets of data (including those in bad packets) received on the network (excluding framing bits but including FCS octets).
PKTS1024TO1518OCTETS	The total number of packets (including bad packets) received that were between 1024 and 1518 octets in length inclusive (excluding framing bits but including FCS octets).
PKTS128TO255OCTETS	The total number of packets (including bad packets) received that were between 128 and 255 octets in length inclusive (excluding framing bits but including FCS octets).
PKTS256TO511OCTETS	The total number of packets (including bad packets) received that were between 256 and 511 octets in length inclusive (excluding framing bits but including FCS octets).

**TABLE 3-15 RMON Statistics (Continued)**

Statistic	Description
PKTS512TO1023OCTETS	The total number of packets (including bad packets) received that were between 512 and 1023 octets in length inclusive (excluding framing bits but including FCS octets)
PKTS64OCTETS	The total number of packets (including bad packets) received that were 64 octets in length (excluding framing bits but including FCS octets).
PKTS65TO127OCTETS	The total number of packets (including bad packets) received that were between 65 and 127 octets in length inclusive (excluding framing bits but including FCS octets).
UNDERSIZE	The total number of packets received that were less than 64 octets long (excluding framing bits, but including FCS octets) and were otherwise well formed.

In the NMS, thresholds are set in the Ether-like Port Management form, using the Port Thresholds tab. Setting the threshold invokes SET PORT command above. To enable the NMS to monitor for a threshold trap and to report this at the NMS as an alarm, select the Configured Collection Node and select *Edit -> Add Polling Objects* to have the NMS poll for the statistic, set a threshold, and create an alarm. Refer to the NMS Administration Guide.

### 3.3.5.3 Fast Ethernet and Fiber-based Interface Monitoring

The following thresholds and counters are especially important to monitor the port for problems or potential problems.

#### 3.3.5.3.1 Fault Counts

Fault Counts are monitored by the system and recorded in port fault counters. They are:

**TABLE 3-16 Port Counter Faults (SHOW INTERFACE=(SLOT. PORT) FAULTCOUNT)**

Counter	Meaning
Loss of Link	Keeps track of the number of times a loss of link condition occurred on the given interface. The counter will wrap
Loss of Signal	Keeps track of the number of times a loss of signal condition occurred on the given interface. The counter will wrap
Loss of Frame	Keeps track of the number of times a loss of frame condition occurred on the given interface
Peer Not Present	Keeps track of the number of times the modem goes offline.

### 3.3.6 Maintenance

#### 3.3.6.1 Logs

##### 3.3.6.1.1 Multicast Logs

Table 3-17 lists the log messages associated with the multicast limits in the Telesyn product.

**TABLE 3-17 Multicast Logs**

Log Message	Meaning	Action / Reference
High Water Mark per Card Exceeded	The card is coming close to the IGMP group limit. The default is 20.	No action is required, although this is a warning.
Channel Limit per Card Exceeded	The IGMP group limit per card set with the SET IGMP Snooping Card (slot) MCASTGROUPLIMIT has been exceeded. The default is 25.	There are too many devices requesting multicast channels on this card.
High Water Mark per Card Cleared	The IGMP group limit per card has dropped below the high water mark.	No action is required, this is information.
MAC Limit per Port Exceeded	The maximum number of multicast devices per port has been exceeded.	Contact the subscriber.
Group Limit per MAC (device) Exceeded	The subscriber device is requesting more channels than allowed.	Check for an STB malfunction and/or contact subscriber.

##### 3.3.6.1.2 FE and FX Port Logs

These are the logs generated by the system. The log messages show that the system has discovered a problem and is trying to fix the problem by disabling and enabling the port to retrain the link

Figure 3-5 shows samples of the three log messages, while Table 3-18 describes the messages.

\* PORT003 2003-08-04 04: 44: 23 2390 FAULT Location: Slot: 17 Port: 11 Description: Port Fault Set Reason Code: Loss Of Link

**FIGURE 3-5 FE and FX Port Log**

**TABLE 3-18 Fast ethernet and Fiber-based Port Logs**

Log Message	Meaning	Action / Reference
Loss of Link	The port is no longer receiving a signal from the far end equipment. This log is normally generated following a Loss of Signal.	The connections or far-end equipment could be at fault.

## 4. Optimizing Voice Services

---

### 4.1 Overview

Voice service can be provided with the following configurations:

- POTS with a call agent using the POTS24 card

In this configuration, the POTS24 card supports VoIP using Media Gateway Control Protocol (MGCP) as the call control protocol to the network gateway as defined in the Line Control Signalling (LCS) architecture. The Telesyn POTS24 card transforms analog POTS calls into IP packets and forward these packets onto an Ethernet network. The network gateway accepts these packets and forwards them to a Class 5 switch via GR-303 trunks.

Furthermore, the POTS24 supports the use of RFC2833 to signal Robbed Bit Signalling (RBS) events when requested by the Internet Protocol Digital Terminal (IPDT, the LCS representation of the MGC or call agent). Line signaling events are sent to the IPDT by the POTS24 for on-hook and off-hook events detected on its lines. Likewise, the IPDT will signal RBS events to the POTS24 in order to condition its lines to facilitate call management (for example, external ringback)

to connect to a phone (or modem or fax machine), and is embedded in ethernet.

- Derived Voice

In this configuration, the Residential Gateway provides the same functionality as the POTS24 card and Telesyn device; it can then connect to a Telesyn device or directly to the network. The connection to the network gateway over GR-303 trunks is the same.

In this section, each configuration is described separately.

---

### 4.2 POTS Only with Call Agent (POTS24 Card)

#### 4.2.1 Overview

**Figure 4-1** shows the physical configuration of Voice call processing using the POTS24 card and Call Agent. The analog loop is converted to an ethernet uplink and then connected with the network.

*Note:* This figure also shows that the POTS24 card can be used for data services, such as a pc or fax, since it can connect to a dial-up analog modem.

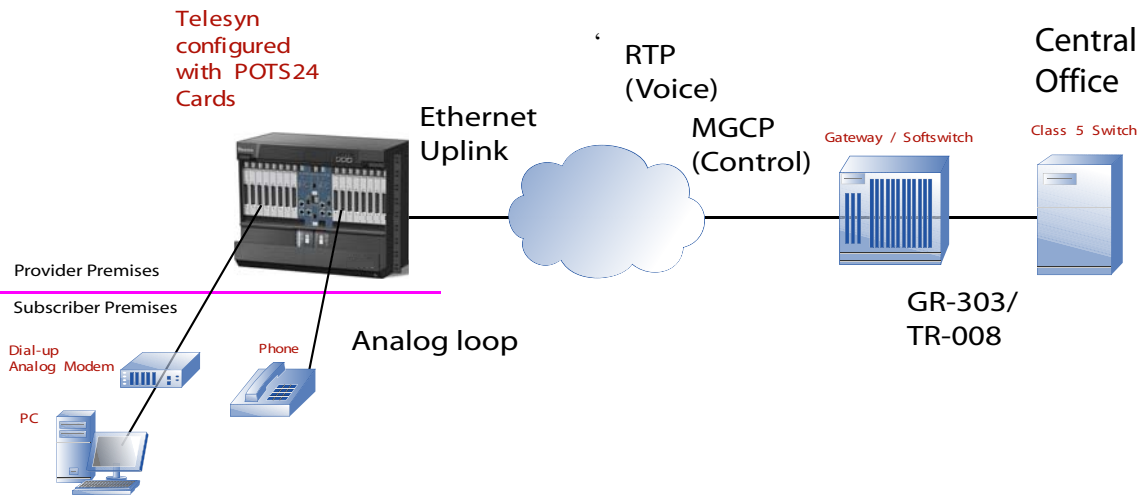

FIGURE 4-1 Voice Service with Call Agent / POTS24 - Physical View

## 4.2.2 Technology

### 4.2.2.1 Standards

Standard	Compliance	Notes
PacketCable LCS	Y	N/A
GR-909	Y	N/A
GR-57	Y	N/A
G.711	Y	N/A
V.34	Y	N/A
V.90	Y	N/A

## 4.2.3 Features

### 4.2.3.1 Data and Video Services

**TABLE 4-1 Feature Interactions for Voice Service**

Feature	Supported?	Notes
<b>Data Service</b>		
(VLAN)	Y	
(UFO)	Y (VLAN based)	
(IGMPv2)	N	
(HVLAN)	N	
(VLAN Translation)	Y	
Multicast channels	N/A	
MAC Limiting	N/A	
MAC Configuration	Y	The MAC address for the card remains in the Forwarding DataBase (FDB) as long as the card is operational and will not be removed due to ageing timer expiration.
DHCP Relay	N	
<b>Link Recovery</b>		
(STP)	N	
(RSTP)	Y	
(LAG - Static)	N	
EPSR	Y	
<b>QOS Classifier</b>		
Ethernet format	N/A	
IP Protocol	N/A	
IP Source	N/A	
IP Destination	N/A	
LSAP	N/A	
MAC Source	N/A	
MAC Dest.	N/A	
Layer 2 Protocol	N/A	
TCP Port Source	N/A	
TCP Port Dest.	N/A	

TABLE 4-1 Feature Interactions for Voice Service (Continued)

Feature	Supported?	Notes
UDP Port Source	N/A	
UDP Port Dest.	N/A	
VID	N/A	
InnerVID	N/A	
Priority	N/A	
IP TOS	N/A	
IP DSCP	N/A	
TCP Flags	N/A	
VID Priority	N/A	
<b>Traffic Management</b>		
VLAN - VC Mapping	N/A	
IP Filtering	N/A	
ARP Filtering	N	
MAC Limiting	N/A	
Remarking	N/A	
Ingress Metering/Policing	Y	
Queue Mapping	Y	
Egress Rate Limiting	N	
No. of Queues	8	
ACL	N	

The POTS24 card supports VLAN for its voice packet transmission. However, the MAC address for the card remains in the Forwarding DataBase (FDB) as long as the card is operational and will not be removed due to ageing timer expiration.

#### 4.2.4 Network Engineering

Traffic models, formulas that result in the max/min numbers for both initial physical needs and parameters that are provisioned.

- Supports line loops up to 18Kft.
- Supports FAX Modem to 14400 b/s and V.90 modems
- Supports Custom Local Area Signalling Services (CLASS) managed by a Class 5 switch, such as Call Forwarding, Caller Identification, Calling Number Delivery, etc.



#### 4.2.4.1 Line Supervision Mode

Only loop start is supported; ground start is not supported. Card Attributes

#### 4.2.4.2 Ring Generator

The ring generator on the POTS24 card has limited output, depending on line loads, as follows:

TABLE 4-2

Ringer Output Voltage	Line Load (in REN)
100Vrms	10REN
90Vrms	13REN
86Vrms	15REN
75Vrms	20REN
65Vrms	25REN
55Vrms	35REN
45Vrms	40REN
shutdown	40REN

The ring generator will gradually reduce output voltage until the load reaches 40 Ringer Equivalency Number (REN). This helps to prevent distortion. If the load goes over 40 REN for more than 600 msec, the generator will shut down for 5 seconds. It will then try to recover and manage the perceived load normally. After the recovery, if more than 40 REN still exists, another shutdown will occur.

### 4.2.5 Hardware Provisioning

#### 4.2.5.1 POTS24 Card

The POTS24 supports all SM card attributes. **However, the POTS24 must have IP, MGCP, and RTP protocol attributes provisioned in association with the card in order to provide service.** Therefore, the POTS24 card cannot be completely auto-provisioned to an in-service state; some manual configuration is required for each card that cannot be specified in the auto-provisioning profiles.

#### 4.2.5.2 Configuring POTS24 Card Protocol Attributes

A virtual Ethernet interface is created using the ADD IP INTERFACE command.

### 4.2.5.3 Configuring MGCP Attributes

The MGCP (Media Gateway Control Protocol, RFC 3435) configuration specifies how the card will communicate with the network call agent for call signaling. Once the IP provisioning is done for the card's virtual Ethernet interface, the MGCP attributes can be provisioned.

**Note:** *Any modification of MGCP parameters requires the card to be disabled.*

### 4.2.5.4 Configuring RTP Attributes

The RTP (Real-Time Protocol, RFC 3550) configuration specifies how the card will exchange bearer packets with the call agent over the network. Once the IP provisioning is done for the card's virtual Ethernet interface, the RTP attributes can be provisioned.

**Note:** *Any modification of RTP parameters requires the card to be disabled.*

*Note:* *Users cannot provision country code, it is internally set to North America.*

### 4.2.5.5 POTS24 Port

Configurable attributes for each line interface specify the capabilities of the line that affect analog waveform transmission and packetization of the analog waveform.

The `SET PORT` command with the `POTS` qualifier is used to modify these attributes.

**Note:** *Modification of these attributes requires the port to be disabled.*

A description of the POTS24 port parameters is included in the Telesyn User Guide. Following are the key parameters for correct configuration:

- `MINPACKETIZATION` - To support Call Waiting with Caller ID, this attribute should be set to 10 milliseconds.
- `MAXPACKETIZATION` - To support Call Waiting with Caller ID, this attribute should be set to 10 milliseconds.
- `BUFFERMODE` - If a user does not have a modem, then `DYNAMIC` at 10 msec delay will work. However, if a modem is ever used, the delay in packets must be deterministic to keep the modems from retraining; therefore, use `STATIC` at 10 msec.

## 4.2.6 Software Engineering

### 4.2.6.1 MGCP Statistics

Statistics supported for the MGCP application running on the POTS24 card are defined in the ATN SNMP Enterprise MIB. This MIB defines proprietary MIBs for the Telesyn product family. For MGCP, the MIB contains the `atnMgcpStatsTable` that contains instances of `atnMgcpStatsEntry`. Supported card specific counters in `atnMgcpStatsEntry` include the following:

The statistics are available anytime the POTS24 card is operationally up. All statistics are cleared when the card out-of-service for any reason. The counters are enabled when the card becomes operational and they continue to increment as long as the card remains in-service.

#### 4.2.6.2 RTP Statistics

Statistics supported for the RTP application running on the POTS24 card are defined in the ATN SNMP Enterprise MIB. This MIB defines proprietary MIBs for the Telesyn product family. For MGCP, the MIB contains the `atnRtpStatsTable` that contains instances of `atnRtpStatsEntry`. Supported port specific counters in `atnRtpStatsEntry` the following:

## 4.3 Derived Voice (Residential Gateway)

### 4.3.1 Overview

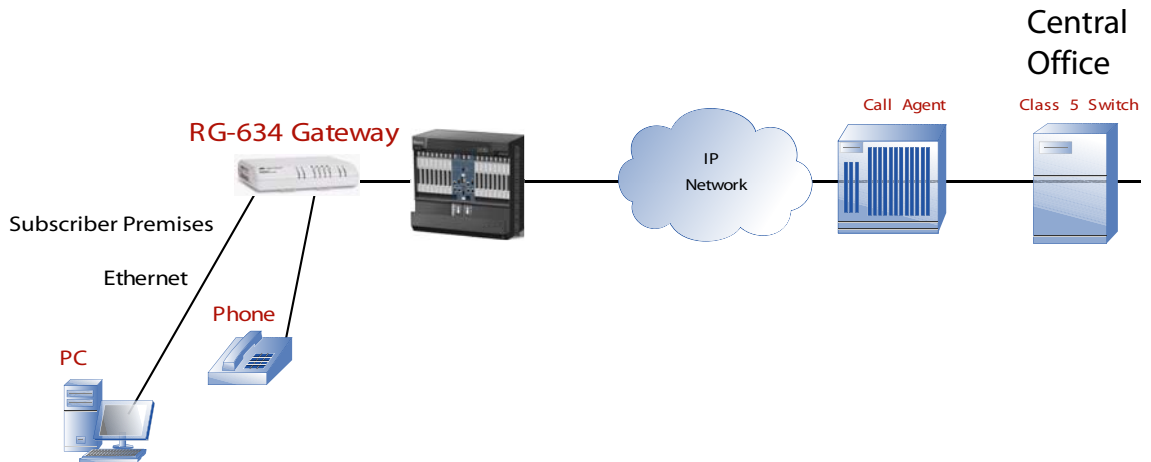

FIGURE 4-2 Derived Voice - Physical View

### 4.3.2 Telesyn Implementation

A RG-634 Residential Gateway is configured at the subscriber's premises which provides an uplink to the IP network.



## 5. Circuit Emulation Service (CES)

### 5.1 Overview

In release 5.0, “Pass-thru” Circuit Emulation Service for both E1 and DS1 circuits is supported on the CES8 SM. In Pass-Thru, the whole DS1/E1 frame is passed. The Telesyn does not terminate/interpret the FDL in Pass-Thru. The only layer terminated at the MAP is the line layer.

### 5.2 Technology

Refer to the *Telesyn Component Specification* for DS1/E1 standards.

### 5.3 Features

Since Circuit Emulation is pass-through service, many of the features listed in are N/A. However, since DS1/E1 data is delay sensitive and is being sent over a packet network, there are some QoS and traffic management issues that are highly important, and these will be discussed in detail.

**TABLE 5-1 Feature Interactions for Circuit Emulation Service**

Feature	Supported?	Notes
<b>Data Service</b>		
(VLAN)	Y	
(UFO)	Y (VLAN based)	
(IGMPv2)	Y	
(HVLAN)	N	
(VLAN Translation)	N	
Multicast channels	N/A	
MAC Limiting	N/A	
MAC Configuration	N/A	

---

## Features

---

**TABLE 5-1 Feature Interactions for Circuit Emulation Service (Continued)**

Feature	Supported?	Notes
DHCP Relay	N/A	
<b>Link Recovery</b>		
(STP)	Y	
(RSTP)	Y	
(LAG - Static)	Y	
EPSR	Y	
<b>QOS Classifier</b>		
Ethernet format	N/A	
IP Protocol	N/A	
IP Source	N/A	
IP Destination	N/A	
LSAP	N/A	
MAC Source	N/A	
MAC Dest.	N/A	
Layer 2 Protocol	N/A	
TCP Port Source	N/A	
TCP Port Dest.	N/A	
UDP Port Source	N/A	
UDP Port Dest.	N/A	
VID	N/A	
InnerVID	N/A	
Priority	N/A	
IP TOS	N/A	
IP DSCP	N/A	
TCP Flags	N/A	
VID Priority	N/A	
<b>Traffic Management</b>		
VLAN - VC Mapping	N/A	
IP Filtering	N/A	
ARP Filtering	N/A	
MAC Limiting	N/A	
Remarking	N/A	

**TABLE 5-1 Feature Interactions for Circuit Emulation Service (Continued)**

Feature	Supported?	Notes
Ingress Metering/Policing	Y	
Queue Mapping	Y	
Egress Rate Limiting	Y	
No. of Queues	8	
ACL	Y	

---

## 5.4 Network Engineering

### 5.4.1 Packet Network Considerations

Transport robustness is important since many characteristics of packet networks are not compatible to constant bit rate services. Packet network congestion, blocking, QoS prioritization, and multiple paths with varying latency, can lead to:

- jitter
- lost packets
- duplicate packets
- packets out of sequence.

All of these error conditions must be engineered into the CES8 configuration; some of these are done automatically by the card, while some are done through configurable parameters.

#### 5.4.1.1 Packet Size

Packet size is directly related to the number of bytes taken from a T1 bit stream to create a packet for the pseudo span. This is user configurable and can range from 1 byte to 1488 bytes. (Refer to the Telesyn User Guide for details.)

Increasing the number of bytes per packet increases end to end latency, and thus adds delay in the TDM circuit. For data applications such as Frame Relay, latency does not significantly degrade the service. However for voice applications, sufficient amounts of delay can result in the need for echo cancellation.

At the other extreme, lower numbers of bytes per packet decrease transport efficiency by increasing the percentage of overhead bytes associated with the packet. Setting the number of bytes per packet too low doesn't provide enough bytes to fill the minimum Ethernet frame of 64 bytes, causing the packet to be filled with dummy information and therefore wasting packet bandwidth.

show the relationship of NUMBYTES and the bandwidth/jitter values.

#### 5.4.1.2 Packet Delay Variation

TDM-based data operates at a constant bit rate. When converting from packet to T1, the CES8 must have a queued packet to "play out". It cannot wait for a packet to arrive without causing errors in the T1. Unfortunately, transit time across a packet network varies from packet to packet. These variations, or **jitter**, in the arrival time of the incoming packets and are commonly referred to as Packet Delay Variation (**PDV**). PDV is a parameter that is measured in milliseconds. PDV has many origins; multiple routes with different transit times, switch congestion, mixed packet sizes, contention with traffic with marked for higher QoS, and router loading.

Generally, the more switching or routing nodes in the pseudo span path, the greater the PDV. In order to compensate for PDV, the CES8 must buffer enough packets to ensure that another packet has arrived before the



current packet has been played out. The CES8 provides buffers that can be configured to absorb up to 60ms of PDV. Increasing the depth of these buffers adds latency and thus delay to the T1.

As mentioned above in the discussion on packet size, latency may not degrade some data services but voice services may require echo cancellation to handle excessive delays.

### 5.4.1.3 End-to-End Latency

Many services carried over T1 are delay sensitive. For example, in voice applications end to end transport latency greater than 25ms generally requires the use of echo cancellers to remove audible reflections from far end 4 to 2 wire hybrid circuits. Therefore it is often important to understand the total end to end transport delay when engineering a T1 over Ethernet circuit.

Calculations of end to end latency must include the following:

1. Packet size - The number of bytes from the T1 stream that are used to form the Ethernet packet.
2. Switch transit delay - The delay incurred as a packet is switched or routed through nodes in the Ethernet network.
3. PDV Buffering - The depth of the jitter buffer on the DCEI8 adds to the end to end delay.

The total latency is determined by adding the contribution of each the factors above. For example, in an EPSR configuration the end to end delay varies depending on which direction traffic is circulating on the ring.

5.4.2 NUMBYTES and Bandwidth Correlation

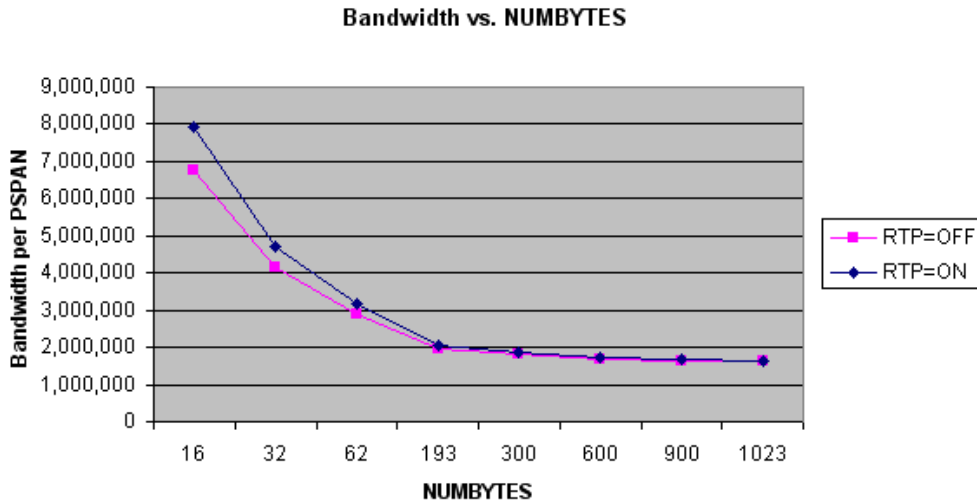

FIGURE 5-1 PSPAN Bandwidth vs. NUMBYTES

Table 6:

NUM-BYTES	Time(ms) per PKT	RTP=ON			RTP=OFF		
		PKT Size	Bandwidth (bps)	% Overhead	PKT Size	Bandwidth (bps)	% Overhead
16	0.08	82	7,913,000	412.5%	70	6,755,000	337.5%
32	0.17	98	4,728,500	206.3%	86	4,149,500	168.8%
62	0.32	128	3,187,613	106.5%	116	2,888,774	87.1%
193	1.00	259	2,072,000	34.2%	247	1,976,000	28.0%
300	1.55	366	1,883,680	22.0%	354	1,821,920	18.0%
600	3.11	666	1,713,840	11.0%	654	1,682,960	9.0%
900	4.66	966	1,657,227	7.3%	954	1,636,640	6.0%
1023	5.30	1089	1,643,613	6.5%	1077	1,625,501	5.3%

NOTE: This does not account for IPG, which is media dependent.

### 5.4.3 NUMBYTES vs. Minimum / Maximum Jitter Values

Figure 5-2 shows graphically the minimum and maximum allowable jitter values for the NUMBYTES that are passed in each packet.

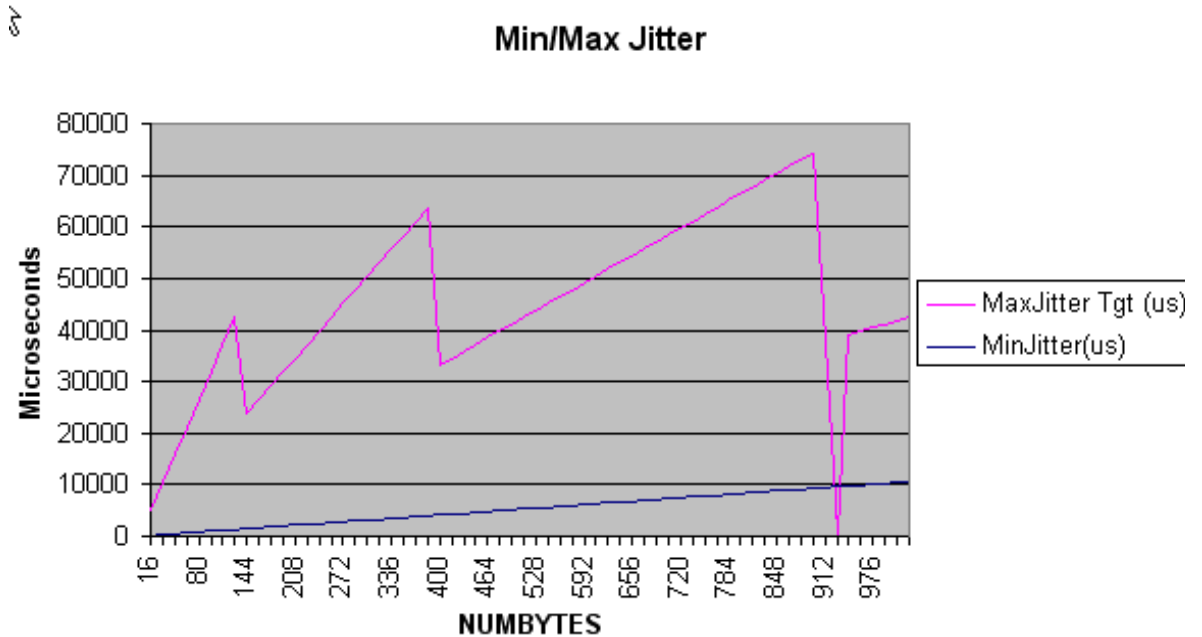

FIGURE 5-2 Allowable Jitter Ranges

Table 5-1 correlates the data in a tabular format, with the following notes:

- Minimum jitter buffer depth - The user can specify any non-0 value, but the CSE8 card will select, at minimum, a jitter buffer length of 2 packets (or the equivalent in microseconds) and round up to the nearest 250us.
- Maximum jitter buffer depth - There are limits on the number of packets that can be queued, as well as limits on the total memory to queue the packets.

TABLE 5-1 Jitter Values

NUMBYTES	Time(us) per PKT <sup>a</sup>	PKT Size <sup>b</sup>	MinJitter(us) <sup>c</sup>	MaxJitter Tgt (us)
16	82	78	164	5248
32	165	94	330	10560
48	248	110	496	15872
64	331	126	662	21184
80	414	142	828	26496
96	497	158	994	31808
112	580	174	1160	37120
128	663	190	1326	42432
144	746	206	1492	47744
160	829	222	1658	53056
176	911	238	1822	58368
192	994	254	1988	63680
208	1077	270	2154	68992
224	1160	286	2320	74304
240	1243	302	2486	79616
256	1326	318	2652	84928
272	1409	334	2818	90240
288	1492	350	2984	95552
304	1575	366	3150	100864
320	1658	382	3316	106176
336	1740	398	3480	111488
352	1823	414	3646	116800
368	1906	430	3812	122112
384	1989	446	3978	127424
400	2072	462	4144	132736
416	2155	478	4310	138048
432	2238	494	4476	143360
448	2321	510	4642	148672
464	2404	526	4808	153984
480	2487	542	4974	159296
496	2569	558	5138	164608
512	2652	574	5304	169920
528	2735	590	5470	175232
544	2818	606	5636	180544
560	2901	622	5802	185856
576	2984	638	5968	191168
592	3067	654	6134	196480
608	3150	670	6300	201792

## Network Engineering

**TABLE 5-1 Jitter Values (Continued)**

NUMBYTES	Time(us) per PKT	PKT Size	Min.Jitter(us)	Max.Jitter Tgt (us)
624	3233	686	6466	51728
640	3316	702	6632	53056
656	3398	718	6796	54368
672	3481	734	6962	55696
688	3564	750	7128	57024
704	3647	766	7294	58352
720	3730	782	7460	59680
736	3813	798	7626	61008
752	3896	814	7792	62336
768	3979	830	7958	63664
784	4062	846	8124	64992
800	4145	862	8290	66320
816	4227	878	8454	67632
832	4310	894	8620	68960
848	4393	910	8786	70288
864	4476	926	8952	71616
880	4559	942	9118	72944
896	4642	958	9284	74272
912	4725	974	9450	37800
928	4808	990	9616	2
944	4891	1006	9782	39128
960	4974	1022	9948	39792
976	5056	1038	10112	40448
992	5139	1054	10278	41112
1008	5222	1070	10444	41776
1023	5300	1085	10600	42400

- a. This includes 62 bytes of header (no FCS because that is not stored in the jitter buffer).
- b. Minimum value for the actual depth is two packets.Target fill is half of this.
- c. The max target fill level is half of the max capacity of the queue.

## 5.5 Software Engineering

### 5.5.1 Statistics

As explained in the User Guide, CES in Release 5.0 includes the following components:

- IP Address/VLAN - This makes up the IP Endpoint or IP Interface of the card (such as VLAN:402.0).
- DS1/E1 Port - The connecting point for the DS1 or E1 link.
- PSPAN - The IP-based encapsulation of the DS1 packets. This is the IP Endpoint and the unique PSPAN ID (such as 402.0.1).

*Note: In Release 5.0, only Circuit Emulation is supported, so far end statistics are not available. (In circuit emulation, the Line and not the Path of the DS1/E1 is terminated; since the far end statistics are embedded in the DS1/E1 frame, the Telesyn device cannot access this information.)*

#### 5.5.1.1 IP Interface - RMON

RMON statistics can be measured for the interface using the `SHOW INTERFACE (if_name> COUNTER ON command`

#### 5.5.1.2 DS1/E1 Interface - PMON

PMON statistics/thresholds for DS1/EI are similar to those for ADSL and SHDSL cards. [Table 5-2](#) lists the statistics and any guidelines for setting thresholds and viewing historical trends.

**TABLE 5-2 PMON Statistics for DS1/E1 Interfaces**

Statistic	Meaning	Description	Threshold Setting	Historical Trends to Watch
LOSS	Loss of Signal Seconds	The number of seconds in which there was one or more LOS defects		No
ES	Errored Seconds	The number of seconds with one or more coding violations and or Loss of Service (LOS) defects		
SES	Serious Errored Seconds	The number of seconds in which coding violations and or Loss of Service (LOS) defects have exceeded a threshold		

**TABLE 5-2 PMON Statistics for DS1/E1 Interfaces**

Statistic	Meaning	Description	Threshold Setting	Historical Trends to Watch
UAS	Unavailable Seconds	The number of seconds the line was unavailable		
CV	Line Coding Violations	A count of Line Coding Violations		

**5.5.1.3 PSPAN Statistics (PMON)**

The collection rules for PSPAN statistics are similar to other PMON statistics (15-minute clock aligned collection windows). lists [Table 5-2](#) lists the statistics and any guidelines for setting thresholds and viewing historical trends.

**TABLE 5-3 PMON Statistics for DS1/E1 Interfaces**

Statistic	Meaning	Description	Threshold Setting	Historical Trends to Watch
LOPSS	Loss of Packet Stream Seconds	Counts the number of seconds when a LOPS defect is present		
ES	ErroredSeconds	Counts the number of seconds when any error conditions occurred (e.g. missed sequence number).  <i>Note: SES is not collected</i>		
LatePkts	Late Packets			
EarlyPkts	Early Packets			
LostPkts	Lost Packets			
PacketsReceived	Number of packets received	Should be a consistent value. Useful in confirming traffic flow.		
BytesReceived	Number of bytes received	Should be a consistent value. Useful in confirming traffic flow.		

TABLE 5-3 PMON Statistics for DS1/E1 Interfaces

Statistic	Meaning	Description	Threshold Setting	Historical Trends to Watch
PacketsSent	Number of packets transmitted	Used to verify that the expected packets are being sent for this p-span while other p-spans are also in operation.		
BytesSent	Number of bytes transmitted	Used to verify that the expected number of bytes are being sent for this p-span while other p-spans are also in operation.		
JitterBufferFillMin	Minimum Level			
JitterBufferFillMax	Maximum Level			
JitterBufferFillAvg	Average Fill Level			



## 6. Ethernet Passive Optical Network (EPON)

---

### 6.1 Overview

Refer to the Telesyn User Guide for an overview of the Ethernet Passive Optical Network implementation using the EPON2 card and the iMG/RG that includes the ONU.

---

### 6.2 Traffic Management

This subsection highlights how traffic management is handled for the EPON configuration.

#### 6.2.1 Classifiers

Filtering is based on VLAN and IPSOURCE address.

IPSOURCE filtering can be done:

- Statically, using ACL or user classifiers
- Dynamically, using the Auto\_IP filtering option on DHCP relay.

Note the following rules for classification; these are enforced by the CLI:

- The VID match rule is required on all IP filters.
- Ingress metering is not supported.
- The user can do only FORWARD and DROP actions (e.g. can't COUNT, remark, etc.).
- There is no support for IP address masks .
- All FORWARD actions precede any DROP actions, and all DROP actions follow any FORWARD actions.

*Note:* These attributes are included in the summary tables in [Section 17.1](#).

#### 6.2.2 QoS (Traffic Queues/Priorities)

With the introduction of the Service Level Agreement (SLA) model, there is a change in how traffic is prioritized as it flows upstream and downstream. Between the OLT and ONU, traffic management is done as follows:

- The SLA provides traffic management per VLAN
- The SLA must take into account all traffic on that VLAN (service, ping, DHCP, etc.)

---

At points outside the OLT-ONU, p-bits/classifiers may still be used at various points; moreover, these are passed through the OLT-ONU. This has the following results:

- In the upstream direction, traffic is passed with no controls from the UNI to the ONU. From the OLT to the ONU, the SLA is used to prioritize traffic flows per VLAN as follows:
  - High - UPDELAYSENSITIVITY=Sensitive
  - Medium - UPDELAYSENSITIVITY=Tolerant , MINUPSTREAMRATE **not**=0
  - Low - MINUPSTREAMRATE=0

At the EPON interface, p-bits may be used with the VPRIORITY setting to separate and prioritize traffic for up to 8 queues.

*Note: The user must be sure that there are no conflicts between the flows set up by the SLA and those by the p-bit settings, since they are separate traffic management tools.*

- In the downstream direction, p-bits/classifiers are set at the EPON interface. For known unicast traffic (non-video and non-BRUUM), the SLA per VLAN is used to prioritize the data flows. At the ONU, the p-bit/classifier settings are passed down to the ONU and are actually applied to the traffic flows.

*Note: Traffic management is therefore not performed by the EPON but by the ONU, which has the interface to the UNI. The ONU is modeled as an Telesyn extension.*

### 6.2.3 Connection Admission Control (CAC)

The CAC function is to ensure the hardware can provide the guarantees configured by the SLAs. There are two types of CAC check on the EPON2 interface:

1. Sum of Minimum Bandwidths - The sum of provisioned minimum bandwidths for the QOSPOLICYs of all logical links on an EPON port must not exceed the bandwidth capacity of that port in either upstream or downstream direction. This limit is slightly below 1G due to administrative overhead (REPORTs, GRANTs, OAMPDUs, etc.). This function is performed in OAM so that CAC can be enforced even if the EPON2 card is not physically present (i.e. when pre-provisioning).

2. Availability of priority categories - This differentiates among three categories of traffic at the queues from the OLT upstream to the EPON switching fabric. There is a number of links allowed in each category at initialization time. The following table shows these categories and the number of links allowed:

**TABLE 6-1 CAC for the EPON2**

Priority Level	Correlation to SLA	Type of Traffic	Number of Links	Total
0	DELAY=SENSITIVE AND Min = Max	Traffic that is sensitive to jitter (e.g. Voice VLAN)	2 per ONU	64
1	DELAY=TOLERANT AND Min > 0	Traffic that can tolerate some jitter, and has some guaranteed bandwidth (e.g. Video VLAN)	2 per ONU, plus 15 additional	64 +15 (79)
2	DELAY=TOLERANT AND Min = 0	Best Effort” traffic (e.g. Internet VLAN, RG Boot VLAN, RG Mgmt VLAN)	2 per ONU	96
				<b>239</b>

*Note: The user must be aware of this allocation when choosing SLAs. Attempts to assign SLAs that exceed the number that are allocated for that type of SLA will be rejected at the CLI.*

## 6.3 Feature Interaction

Following are the feature interactions/limitations for the EPON2:

- The EPON2 does not support the MAC limiting feature.
- The EPON2 does not support the STB Mobility feature.
- ONU switching from ONU to ONU connected to the same EPON2 is not supported in this release.
- Each ONU supports up to 6 VLANs, and up to 24 different VIDs among all the ONUs that are connected to the EPON2.
- The EPON2 card does not support FLOODUNKNOWN=ON the same way as other cards/interfaces.
- Upgrading the EPON2 load upgrades the software on all the ONUs associated with the EPON2 automatically, to ensure they are in synch with the OLT configuration on the EPON2 card.



## 7. Special Network Configurations

---

### 7.1 Overview

When configuring the overall network that is going to support the voice, video, and data services, certain topologies (such as RSTP and EPSR) are used to provide a level of protection so that services are not affected in case of an outage of a network component, or that there is a minimum of service interruption. These topologies as they relate to the Telesyn features are explained in the Telesyn User Guide. Moreover, in the feature table in each Section of this document, a table lists for each service the kinds of topologies that can be used.

There are, however, some special configurations that allow the customer to provide a more efficient (or cost-effective) way to offer the services using special or existing facilities. This leverages the customer's ability to make these services available using the Telesyn components.

---

### 7.2 FE10 Upstream Interface

#### 7.2.1 Overview

The Telesyn User Guide explains the configuration that was available in release 5.0, and that in release 6.0 many restrictions were removed so that voice, data, and video services are all supported with an FE/FX interface with an upstream network interface. Moreover, IGMP snooping is available on an FE/FX port that is configured as a network interface.

#### 7.2.2 Feature Interaction

[Table 7-1](#) lists the features that are available for the FE/FX10 upstream interface.

**TABLE 7-1 Feature Interactions for FE10 Upstream - Voice, Data, and Video Service**

Feature	Supported?	Notes
<b>Data Service</b>		
(VLAN)	Y	
(UFO)	N	An FE interface can be added to a UFO VLAN, and the FE interface can be designated as having upstream forwarding mode. The user can therefore add FE ports to UFO VLANs.

TABLE 7-1 Feature Interactions for FE10 Upstream - Voice, Data, and Video Service (Continued)

Feature	Supported?	Notes
IGMPv2 - IGMP Snooping	Y	By default, IGMP snooping is enabled on FE/FX ports.
HVLAN	N	
VLAN Translation	N	
Multicast channels	Y	
MAC Limiting	Y	
MAC Configuration	Y	
DHCP Relay	Y	By default, DHCP relay is disabled, and the user can enable it so the network FE/FX can be the interface to the DHCP server.
<b>Link Recovery</b>		
(STP)	Y	
(RSTP)	Y	
(LAG - Static)	N	
EPSR	Y	An FE interface cannot be added to an EPSR domain as primary or secondary interface via CLI or NMS, but a VLAN associated with an FE interface <b>can</b> be added to an EPSR domain.
<b>QOS Classifier</b>		
Ethernet format	Y	
IP Protocol	Y	
IP Source	Y	
IP Destination	Y	
LSAP	Y	
MAC Source	Y	
MAC Dest.	Y	
Layer 2 Protocol	Y	
TCP Port Source	Y	
TCP Port Dest.	Y	
UDP Port Source	Y	
UDP Port Dest.	Y	
VID	Y	
InnerVID	N	
Priority	N	
IP TOS	N	
IP DSCP	N	

**TABLE 7-1 Feature Interactions for FE10 Upstream - Voice, Data, and Video Service (Continued)**

Feature	Supported?	Notes
TCP Flags	N	
VID Priority	N	
<b>Traffic Management</b>		
VLAN - VC Mapping	Y	
IP Filtering	Y	
ARP Filtering	Y	
MAC Limiting	Y	
Remarking	N	
Ingress Metering/Policing	Y	
Queue Mapping	Y	
Egress Rate Limiting	N	The 1000 Mbps FE10 egress rate is limited to the DS3 transport rate (40-44Mbps).
No. of Queues	8	
ACL	Y	

*Note: It is also possible to not use a redundant STP configuration; an FE10 uplink would simply support a number of VLANs. However, if the link is broken, all traffic associated with that VLAN (such as voice service) would be lost, so this is not recommended.*





## 8. Optimizing All Services (Triple Play)

---

### 8.1 Overview

Using NMS for steps, so will use “wizards” whenever possible.

Really boils down to Network Services Data node and Provision Card Form.

#### 8.1.1 Sample Configuration - Network Level

This figure will be shown in various ways to highlight what is being provisioned.

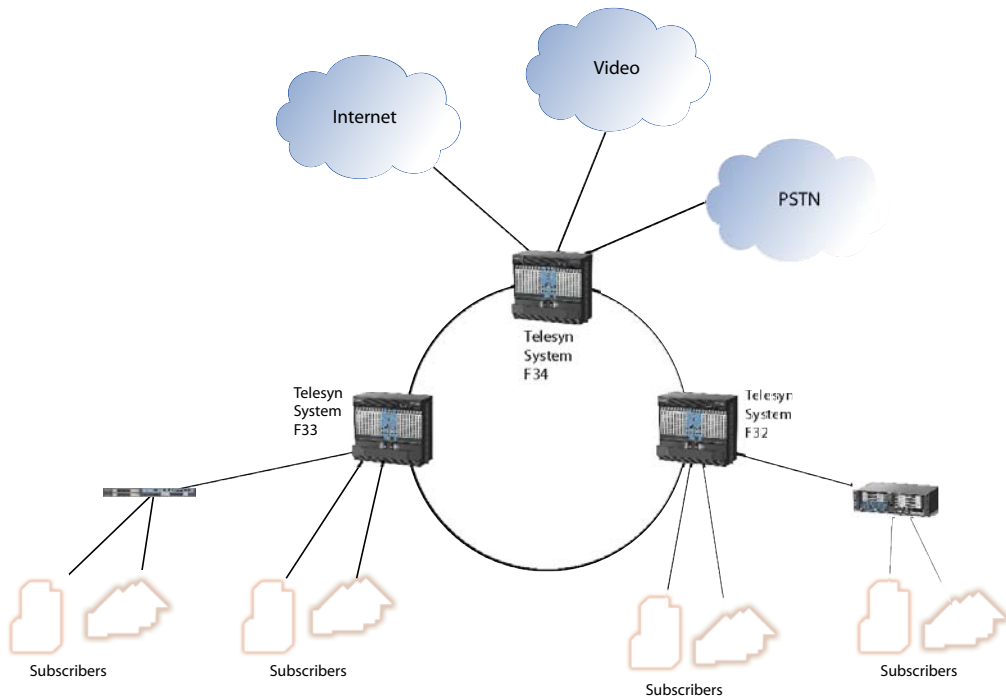

**FIGURE 8-1 Example Triple Play Configuration (High Level)**

## 8.2 Provisioning Example - Overview

Figure 8-1 is a mapping of all the tasks involved in setting up a multi-service system, and includes a topology that provides a level of protection for each service.

The NMS menu selections are in bold/italic, with -> for accessing a submenu, such as ***Policy -> Add Policy***.

Following this table are the detailed steps involved to datafill a sample configuration.

*Note:* As Figure 8-1 shows, the NMS is the primary interface for performing the configuration tasks, and the CLI is used only when a task cannot be done with the NMS.

**TABLE 8-1 Major Tasks to Configure Triple Play for Telesyn Devices**

Task	CLI / NMS (Highlight where CLI only)	Main Steps	Reference
<b>Nodes (One Time Only)</b>			
MAP Devices	NMS	1. Using CLI, set up critical attributes 2. NMS discovers devices and adds them to network	
Servers	CLI		
Routers	NMS		
<b>Third Party Interfaces (One Time Only)</b>			
GenBand 6		MGCP	
Call Agent Attributes			
<b>Network Topology (Multiple Telesyn Devices, One Time Only)</b>			
Physical Links			
Network VLANs		Create Network VLANs	
Protection		Create Protection Configuration	
<b>Policies and Profiles (One or Multiple Telesyn Devices, One Time Only)</b>			
Create Profiles Devices		<i><b>Network Services -&gt; Profiles -&gt; Create Telesyn Device Profile</b></i> For Telesyn devices, Profile Associates QoS Priority with 4 or 8 Class of Service (COS) Queue Mapping	

TABLE 8-1 Major Tasks to Configure Triple Play for Telesyn Devices

Task	CLI / NMS (Highlight where CLI only)	Main Steps	Reference
Create QoS Policies	<ol style="list-style-type: none"> <li>1. Create QoS Traffic Flows</li> <li>2. Create QoS Priority Action</li> <li>3. Create QoS Traffic Action</li> <li>4. Create QoS Policy Action</li> <li>5. Define a QoS Policy</li> </ol>	For ADSL, this would be included in a Triple Play Policy.	
Create Profiles for Port Types	<ol style="list-style-type: none"> <li>1. Create Profile for ADSL Port</li> <li>2. Create Profile for Ether-like Port</li> <li>3. Create Profile for SHDSL Port</li> <li>4. Create Profile for POTS Port</li> <li>5. Create Profile for CES8 Port</li> </ol>	<p><i>Network Services -&gt; Profiles -&gt; Create ADSL Port Profile</i></p> <p>For ADSL, this has three tabs:</p> <ul style="list-style-type: none"> <li>• General</li> <li>• VLAN/VC Information</li> <li>• ATU-C and ATU-R Thresholds</li> </ul>	
Modify Profiles	<ol style="list-style-type: none"> <li>1. In Profile table, right click on profile and select <i>Deploy Profile</i>.</li> </ol>		
POTS Card Attributes		These are attributes that cannot be defined by the Card Profile (Auto-Prov)	
Deploy Profiles	Right click on a profile in the Profiles table and select Deploy Profile	For ADSL, the ports selected can be across multiple different device types.	
<b>Customer Attributes (Per Customer) - <i>Network Services -&gt; Profiles -&gt; Create Telesyn Device Profile</i></b>			
Create Customer ID	On <b>Provision New Triple Play Customer</b> Form, enter value for Description (Customer ID).	Usually matches subscriber number (nxx-xxxx)	

TABLE 8-1 Major Tasks to Configure Triple Play for Telesyn Devices

Task	CLI / NMS (Highlight where CLI only)	Main Steps	Reference
Provision Video/Data Service	On <b>Provision New Triple Play Customer</b> Form, Video/Data Service Configuration Panel, enter values for Video/Data Service Configuration.	<p>For ADSL, Profiles associated with ADSL are automatically included in Profile pull-down.</p> <p>If VLAN is included in Profile, VLAN settings are greyed out.</p> <p>If IGMP Snooping is off in Profile, cannot do MAC searching, for STB MAC Adrs are greyed out.</p> <p>If the port uses DHCP filtering, the IP Filtering ranges are greyed out.</p>	
Provision Voice Service			
Provision Derived Voice Service			